

2

Chemical bonding

- What are the principle geometrical consequences of ionic, covalent and metallic bonding?
- What orbitals are involved in multiple bond formation between atoms?
- What are allowed energy bands?

Theories of chemical bonds have three important roles. First, they must explain the cohesion between atoms. In addition, they must account for the concept of chemical valence. Valence is the notion of the 'combining power' of atoms. Chemists have long known that atoms show a characteristic valence, depicted as little hooks in textbooks of 100 years ago. Hydrogen and chlorine had a valence of one (i.e. one hook each); oxygen had a valence of two, nitrogen three and carbon four. Although this concept gives correct chemical formulae – water (H_2O), ammonia (NH_3), methane (CH_4), and so on – the fundamental understanding of valence had to wait for the advent of quantum theory. In addition to explaining cohesion and valence, one of the important aspects of any theory of bonding is to explain the geometry of molecules and solids. For example, why is a water molecule angular, and why

does salt (NaCl) exist as crystals and not as small molecules?

It is important to remember that chemical bonds describe the electron density between the atomic nuclei. They are not best considered as rigid sticks or hooks. It is not surprising, therefore, that the most rigorous way to obtain information about the chemical bonds in a solid is to calculate the interaction energies of the electrons on the atoms that make up the material. Fortunately, for many purposes, trends in the chemical and physical properties of solids can usually be understood with the aid of simple models. Three ideas normally suffice to describe strong chemical bonds, called ionic, covalent and metallic bonding.¹ In this chapter, the origins of cohesion, valence and geometry are discussed for each of these three bonding models.

2.1 Ionic bonding

2.1.1 Ions

Ions are charged species that form when the number of electrons surrounding a nucleus varies slightly

¹Remember that chemical bonds are never pure expressions of any one of these concepts, and the chemical and physical properties of solids can be explained only by applying selected aspects of all of these models to the material in question. The fact that a solid might be discussed in terms of ionic bonding sometimes and in terms of metallic bonding at other times simply underlines the inadequate nature of the models.

from that required for an electrically neutral atom. The result can be a positively charged particle, a cation, if there are too few electrons, or a negatively charged particle, an anion, if there are too many. Metals tend to lose electrons and form cations – for example, Na^+ , Mg^{2+} and Al^{3+} . The charge on the ions, written as a superscript, is equal to the number of electrons lost. Nonmetals tend to form anions – for example, F^- , O^{2-} , N^{3-} . The charge on the ions, written as a superscript, is equal to the number of electrons gained. Groups of atoms can also form ions. These are normally found as anions – for example, carbonate (CO_3^{2-}) and nitrate (NO_3^-) ions. Ions are called monovalent if they carry a charge of ± 1 , divalent if they carry a charge of ± 2 , trivalent if they carry a charge of ± 3 and so on. This does not depend upon the number of atoms in an ion. Thus, both Zn^{2+} and CO_3^{2-} are regarded as divalent ions. The size and shapes of ions is deferred until later in this chapter.

2.1.2 Ionic bonding

Central to the idea of ionic bonding is that positive and negative ions attract each other. The resulting ion pair will be held together by electrostatic attraction. Such a bond is called an ionic bond. Key features of ionic bonding are that electrostatic interactions are long-range and nondirectional. The electrostatic attraction will tend to decrease the distance between oppositely charged ions continuously. At some interionic distance, the electron clouds of the ions begin to interact and lead to repulsion between the ions. Ultimately, the two opposing energies will balance and the ions will adopt an equilibrium separation. At this point, the overall bonding energy is the difference between the attractive and repulsive terms:

$$\begin{aligned} \text{ionic bonding energy} &= \text{electrostatic attraction} \\ &\quad - \text{repulsive energy;} \end{aligned}$$

that is,

$$E_{\text{bond}} = E_{\text{electro}} - E_{\text{rep}}$$

An advantage of the ionic bonding model is that these energies can be calculated. This, in turn, allows one to estimate other properties of ionic solids, including mechanical properties.

2.1.3 Madelung energy

The electrostatic potential energy between a pair of ions can be calculated if the ions are replaced by appropriate point charges. Thus the electrostatic energy of a pair of monovalent ions such as Na^+ and Cl^- , which we can define as E_e , is given by:

$$E_e = \frac{(+e)(-e)}{4\pi\epsilon_0 r} = \frac{-e^2}{4\pi\epsilon_0 r} \quad (2.1)$$

where the point charges on the interacting species are $\pm e$, the distance separating the charges is r , and ϵ_0 is the vacuum permittivity. The value of ϵ_0 is $8.854 \times 10^{-12} \text{ F m}^{-1}$, e is measured coulombs and r is in metres. The negative charge arises because one ion has a positive charge and one a negative charge. The energy is zero when the ions are infinitely far from each other, and a negative overall energy means a stable pairing (Figure 2.1).

Although it is obvious that a pair of oppositely charged ions will be attracted, it is by no means clear that a collection of ions will hold together, because ions with the same charge repel each other

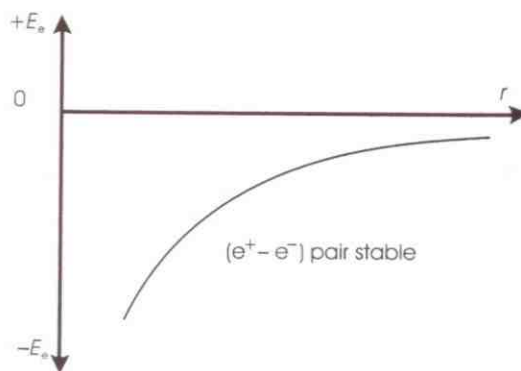

Figure 2.1 The attractive potential energy between a pair of monovalent ions, E_e , as a function of interionic separation, r . The energy is set at zero for ions that are at infinite separation

just as those with opposite charges attract each other. The resultant overall attraction or repulsion will depend on the number of ions and their location relative to one another. The computation of the energy of a cluster of point charges replacing real ions requires several steps.

- Step 1: calculate the total interaction energy, with use of an equation similar to Equation (2.1), between 'ion 1' and all the other ions in the cluster; the interaction is given a plus or minus sign depending on whether the ions have the same or opposite charges.
- Step 2: repeat this summation for all the other ions in the cluster.
- Step 3: divide the total energy calculated by two, as each ion will be counted twice.

The energy so derived is called the Madelung energy of the cluster.

It is found that the electrostatic energy of an ionic crystal has a form identical to that of Equation (2.1) multiplied by a constant that arises from the geometry of the crystal, the arrangement of the ions in space, and a term representing the charges on the ions:

$$E_e = \left(\frac{-e^2}{4\pi\epsilon_0 r} \right) \times (\text{geometry}) \times (\text{ionic charges}) \quad (2.2)$$

The term reflecting the geometry of the structure is called the Madelung constant. Equation (2.2) is the electrostatic energy per pair of ions. The energy is most conveniently expressed per mole of compound. Thus, the electrostatic energy per mole of a crystal of the *halite* (NaCl) structure, containing equal numbers of ions of charge $+Ze$ and $-Ze$, is:

$$E_e = N_A \left(\frac{-e^2}{4\pi\epsilon_0 r} \right) \alpha Z^2 \quad (2.3)$$

where N_A is Avogadro's constant, α is the Madelung constant of the *halite* structure (equal to 1.748), and

r is the nearest equilibrium distance between neighbouring ions in the crystal. As in Equation (2.1), the negative sign arises because the charge on the cations is $+Ze$ and the charge on the anions is $-Ze$. An overall negative value of the electrostatic energy means that ionic *halite* structure crystals are stable. This equation is applicable to all crystals with the *halite* structure, irrespective of the ions that make up the crystal, and can be used with solids as diverse as NaCl itself ($Z_1 = Z_2 = 1$), magnesium oxide (MgO; $Z_1 = Z_2 = 2$) or lanthanum phosphide (LaP; $Z_1 = Z_2 = 3$).

In a structure in which the ions have different charges, such as the *fluorite* structure of CaF_2 , the charge contribution is more complicated. In the case of a compound $M_m X_n$ the electrostatic energy is given by:

$$E_e = -N_A \frac{e^2}{4\pi\epsilon_0 r} \alpha (Z_M Z_X) \frac{m+n}{2} \quad (2.4)$$

where, to maintain charge neutrality, $mZ_M = nZ_X$. The Madelung constant defined by this equation is called the reduced Madelung constant. Alternative definitions are used in some sources. The differences are explained in Section S1.4. Madelung constants for all the common crystal structures have been calculated. Some are listed in Table 2.1. Surprisingly, the reduced Madelung constant is very similar for a wide range of structures, and is equal to 1.68 ± 0.08 , or about 5%, as is apparent from Table 2.1. This means that the approximate electrostatic energy of any crystal structure can be estimated as long as the chemical formula is available, by using Equation [2.4] and a value of 1.68 for α .

Table 2.1 Reduced Madelung constants, α

Structure	Formula	Example	α
Halite	M^+X^-	NaCl	1.748
Caesium chloride	M^+X^-	CsCl	1.763
Sphalerite	$M^{2+}X_2^{2-}$	ZnS	1.638
Wurtzite	$M^{2+}X_2^{2-}$	ZnO	1.641
Fluorite	$M^{2+}X_2^{2-}$	CaF_2	1.68
Rutile	$M^{4+}X_2^{2-}$	TiO_2	1.60

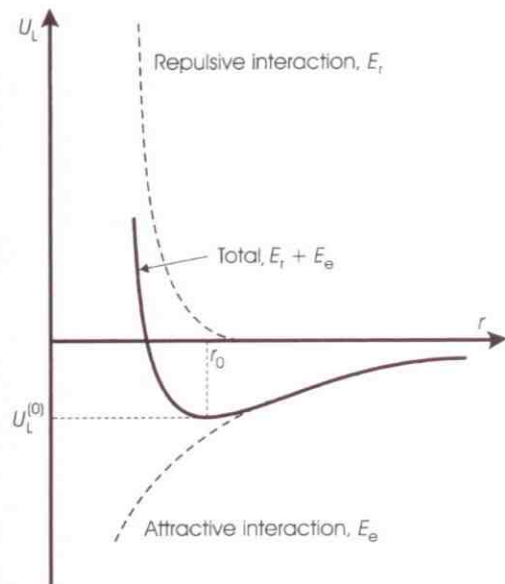

Figure 2.2 The total potential energy, U_L , between monovalent ions as a function of the ionic separation, r . The total energy is the sum of the attractive and repulsive potential energy terms. The lattice energy, $U_L^{(0)}$, corresponds to the minimum in the total energy curve, reached at an interionic separation of r_0 .

2.1.4 Repulsive energy

Ions are not simply point charges and as they are brought together their closed electron shells begin to overlap and, for quantum mechanical reasons, repulsion sets in. This increases sharply as the interionic distance, r , decreases until, neglecting other forces, a balance is obtained with the electrostatic attractive forces (Figure 2.2). The repulsive potential energy, E_r , can be formulated in a number of ways. One of the first to be used was an empirical expression of the type

$$E_r = \frac{B}{r^n} \quad (2.5)$$

where B and n are constants. The value of n can be derived from compressibility measurements. Larger ions are more compressible and have larger values

Table 2.2 Values of the constant n [Equation (2.5)]

Ion configuration	Example	n
He	Li^+	5
Ne	Na^+, F^-	7
Ar	K^+, Cl^-	9
Kr	Rb^+, Br^-	10
Xe	Cs^+, I^-	12

of n . Some values are given in Table 2.2. An average value is used for ionic combinations that have different electron configurations. For example, a value of 6 can be used for the compound LiF. Other ways of describing the repulsive energy are given in the Section 2.1.5.

2.1.5 Lattice energy

The total potential energy of an ionic crystal, which is often referred to as the lattice energy, U_L , per mole, may be represented as the sum of the electrostatic and repulsive energy terms. For a halite structure crystal, MX , by summing Equations (2.3) and (2.5), we obtain the lattice energy, U_L , per mole:

$$U_L = E_e + E_r = \frac{-N_A \alpha Z^2 e^2}{4 \pi \epsilon_0 r} + \frac{N_A B}{r^n} \quad (2.6)$$

The energy is a function of the distance between the ions, r , and at equilibrium this energy must pass through a minimum (Figure 2.2). Thus, we can write:

$$\frac{dU_L}{dr} = \frac{N_A \alpha Z^2 e^2}{4 \pi \epsilon_0 r^2} - \frac{n N_A B}{r^{n+1}} = 0$$

This allows the constant B to be eliminated, to give:

$$U_L^{(0)} = \left(\frac{N_A \alpha Z^2 e^2}{4 \pi \epsilon_0 r_0^2} \right) \left(1 - \frac{1}{n} \right) \quad (2.7)$$

where $U_L^{(0)}$ is the equilibrium value of the lattice energy and r_0 is the equilibrium value of the interionic separation. Values of the lattice energy can be calculated by using experimental values for the equilibrium separation of the ions, r_0 . The

results are in good agreement with experimental determinations of lattice energy.

The advent of high-speed computers has made the calculation of lattice energies and other aspects of an ionic bonding model straightforward. The approach is similar to that outlined above. The lattice energy is derived by summing electrostatic interactions and including a repulsive potential, just as outlined. The advantage of computer routines is that it is possible to include effects such as crystal vibration and terms such as ionic polarisation as well as more sophisticated repulsive potentials. These repulsive potentials are called pair potentials.

Two forms are commonly employed. One is an empirical expression of the type:

$$E_r = +N_A B \exp\left(\frac{-r}{r^*}\right) \quad (2.8)$$

where B and r^* are constants that are structure-sensitive. Values of r^* can be derived from compressibility measurements. Linking Equation (2.8) with the electrostatic energy term, and eliminating the constant B , as above, gives an equation for the lattice potential energy called the Born-Mayer equation:

$$U_L^{(0)} = \left(\frac{N_A \alpha Z^2 e^2}{4 \pi \epsilon_0 r_0}\right) \left(\frac{1 - r^*}{r_0}\right) \quad (2.9)$$

where the symbols have the same meaning as before. Another equation combines aspects of Equations (2.5) and (2.8). It is a form of a more general *Buckingham potential*, and is written as:

$$E_r = +B \exp\left(\frac{-r}{\rho}\right) - \frac{C}{r^6} \quad (2.10)$$

where B , C and ρ are parameters that vary from one ion pair to another, and are determined empirically.

2.1.6 The formulae and structures of ionic compounds

In order to understand the valence of ions it is necessary to consider the electronic configuration in more detail. The gain or loss of electrons is most

often such as to produce a stable closed-shell configuration, found in the noble gas atoms of Group 18 of the periodic table. Hence, atoms to the left-hand side of the periodic table tend to lose electrons. For example, sodium (Na), with a configuration $[\text{Ne}] 3s^1$, forms a sodium ion (Na^+), with configuration $[\text{Ne}]$. Atoms on the right-hand side of the periodic table tend to gain electrons to form a noble gas configuration. For example, chlorine (Cl), with a configuration $[\text{Ne}] 3s^2 3p^5$, readily gains an electron to form an anion (Cl^-), with a configuration $[\text{Ar}]$.

Ions that occur in the middle of the periodic table have configurations that are different from that of the noble gases. Elements following the d-block transition metals tend to have an outer electron configuration d^{10} . For example, the electron configuration of silver (Ag) is $[\text{Kr}] 5s^1 4d^{10}$. To gain a noble gas configuration, the silver atom would have to lose 11 electrons or gain 7 electrons. Each of these alternatives is energetically unreasonable. However, if the silver atom loses the single 5s electron it will still have a closed-shell format, with a filled d^{10} shell outermost. This configuration is relatively stable, and the univalent ion Ag^+ , with a configuration $[\text{Kr}] 4d^{10}$, is stable. The other elements in the group – copper (Cu) and gold (Au) – are similar. They also have the configuration [noble gas] d^{10} . The elements zinc (Zn), cadmium (Cd) and mercury (Hg), with a [noble gas] $d^{10} s^2$ outer electron configuration, tend to lose the s electrons to form Zn^{2+} , Cd^{2+} and Hg^{2+} ions with a configuration [noble gas] d^{10} .

Atoms in at the lower part of Groups 13, 14 and 15 are able to take two ionic states. For example, tin (Sn) has an outer electron configuration $[\text{Kr}] 4d^{10} 5s^2 5p^2$. Loss of the two p electrons will not leave the ion either with a noble gas configuration or with a d^{10} configuration but it will still possess a series of closed shells that is moderately stable. This is the Sn^{2+} state, with a configuration of $[\text{Kr}] 5s^2 6d^{10}$. However, loss of the two s electrons will produce the stable configuration $[\text{Kr}] 6d^{10}$ of Sn^{4+} . The atoms that behave in this way are characterised by two valence states, separated by a charge difference of +2. The examples are indium $[\text{In} (1+, 3+)]$, thallium $[\text{Tl} (1+, 3+)]$, tin $[\text{Sn} (2+, 4+)]$, lead $[\text{Pb} (2+, 4+)]$, antimony $[\text{Sb} (3+, 5+)]$

and bismuth [Bi (3+, 5+)]. When present, the pair of s electrons has important physical and chemical effects, and ions with this configuration are called lone-pair ions.

The transition metal ions generally have a number of d electrons in their outer shell, and because the energy difference between the various configurations is small, the arrangement adopted will depend upon a variety of external factors, such as the geometry of the crystal structure (see also Chapter 12 and Section S4.5). The lanthanides have an incomplete 4f shell of electrons, and the actinides an incomplete 5f shell. In these elements, the f orbitals are shielded from the effects of the surrounding crystal structure. The d and f electrons control many of the important optical and magnetic properties of solids.

The formula of an ionic compound follows directly from the idea that cations have integer positive charges, anions have integer negative charges and ionic compounds are neutral. Consider a crystal of sodium chloride, NaCl. Each Na^+ cation has a charge of $+1e$. Each Cl^- anion has a charge of $-1e$. As crystals of sodium chloride are neutral, the number of Na^+ ions and Cl^- ions must be equal. The chemical formula is Na_nCl_n , that is, NaCl. Similarly, a magnesium Mg^{2+} ion united with an oxygen O^{2-} ion will form a compound of formula MgO, magnesium oxide. It is necessary for two monovalent (M^+) cations to combine with a divalent (X^{2-}) anion to form a neutral unit M_2X – for example, sodium oxide (Na_2O). Similarly, a divalent (M^{2+}) cation will need to combine with two monovalent (X^-) anions to give neutral MX_2 – for example, magnesium chloride (MgCl_2). Trivalent (M^{3+}) cations need three monovalent anions – for example, aluminium chloride (AlCl_3). Two trivalent cations need to combine with three divalent anions to give a neutral unit – for example, aluminium oxide (Al_2O_3).

2.1.7 Ionic size and shape

The concept of allocating a fixed size to each ion is an attractive one and has been extensively utilised. Ionic radii are generally derived from X-ray crystal-

lographic structure determinations (Chapter 5). This technique only gives a precise knowledge of the distances between the atoms in an ionic crystal. To derive ionic radii, it is assumed that the individual ions are spherical and in contact. The radius of one commonly occurring ion, such as the oxygen ion, O^{2-} , is taken as a standard. Other consistent radii can then be derived by subtracting the standard radius from measured interionic distances.

The ionic radius quoted for any species depends upon the standard ion by which the radii were determined. This has led to a number of different tables of ionic radii. Although these are all internally self-consistent, they have to be used with thought. Additionally, cation radius is found to be sensitive to the surrounding coordination geometry. The radius of a cation surrounded by six oxygen ions in octahedral coordination is different from that of the same cation surrounded by four oxygen ions in tetrahedral coordination. Similarly, the radius of a cation surrounded by six oxygen ions in octahedral coordination is different from that of the same cation surrounded by six sulphur ions in octahedral coordination. Ideally, tables of cationic radii should apply to a specific anion and coordination geometry. Representative ionic radii are given in Figures 2.3(a) and 2.3(b).

Several trends in ionic radius are apparent:

- Cations are usually smaller than anions, the main exceptions being the largest alkali metal and alkaline earth metal cations, all larger than the fluorine ion F^- . The reason for this is that removal of electrons to form cations leads to a contraction of the electron orbital clouds as a result of the relative increase in nuclear charge. Similarly, addition of electrons to form anions leads to an expansion of the charge clouds as a result of a relative decrease in the nuclear charge.
- The radius of an ion increases with atomic number.
- The radius decreases rapidly with increase of positive charge for a series of isoelectronic ions such as Na^+ , Mg^{2+} , Al^{3+} , all of which have the electronic configuration [Ne]. Note that the rea-

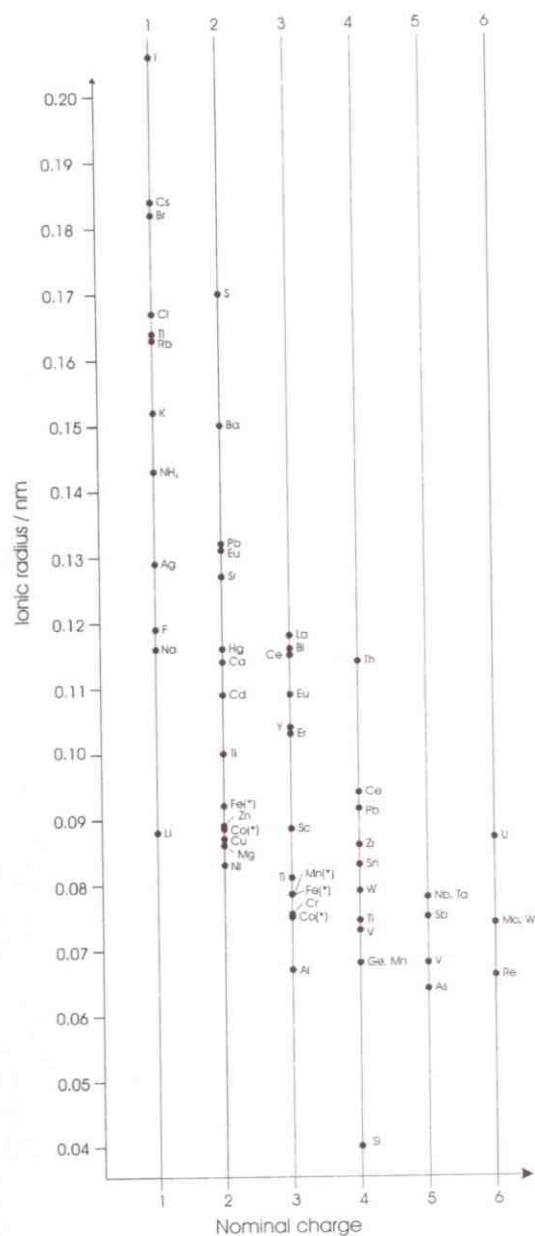

(a)

Figure 2.3 Ionic radii for ions commonly found in solids: (a) graphical representation; (b) periodic table. Note: a superscript *, indicates a high-spin configuration (Section S4.5); cation radii are those for ions octahedrally coordinated to oxygen, except where marked with a t, which are for ions in tetrahedral coordination

charges on cations in solids are generally smaller than the formal ionic charges expressed in isolated ions, and the effect will be smaller in solids than the tables of ionic radii suggest.

- Successive valence increases decrease the radius. For example, Fe^{2+} is larger than Fe^{3+} .
- An increase in negative charge has a smaller effect than an increase in positive charge. For example, F^- is similar in size to O^{2-} , and Cl^- is similar in size to S^{2-} .

Although the majority of the ions of elements can be considered to be spherical, the lone-pair ions are definitely not so. These ions – In^+ , Tl^+ , Sn^{2+} , Pb^{2+} , Sb^{3+} and Bi^{3+} – tend to be surrounded by an irregular coordination polyhedron of anions. This is often a distorted trigonal bipyramid, and it is hard to assign a unique radius to such ions.

Complex ions, such as CO_3^{2-} and NO_3^- , are not spherical, although at high temperatures rotation often makes them appear spherical.

2.1.8 Ionic structures

Ionic bonding is nondirectional. The main structural implication of this is that ions simply pack together to minimise the total lattice energy. There have been many attempts to use this simple idea to predict the structure of an ionic crystal in more detail. This approach was of great importance in the early days of X-ray crystallography, where the investigator had more or less to guess at a model structure to start with by using chemical and physical intuition, and any help that could be obtained from the ionic model was to be welcomed. At present, X-ray techniques allow structures to be solved without such input.

The early structure-building rules, based on ionic bonding guidelines, are still of value, however, in understanding some of the patterns underlying the multiplicity of crystal structures that are known. A simple assumption is that crystals are built of hard spherical ions linked by nondirectional ionic bonding. In terms of this idea, a structure is made up of

Charge state																									
+1		+2		+3		+4		+5		+6		+4		+3		+2		+4		+5		-2		-1	
+1		+2		+3		+4		+5		+6		+4		+3		+2		+4		+5		-2		-1	
Li 0.088	Be 0.041 (†)																	B 0.026 (†)	C	N	O 0.126	F 0.119			
Na 0.116	Mg 0.086																	Al 0.067	Si 0.040 (†)	P	S 0.170	Cl 0.167			
K 0.1521	Ca 0.114	Sc 0.0885	Ti 0.0745 (0.081)	V 0.068 (0.073) [0.078]	Cr [0.0755]	Mn [0.068] [0.079*] [0.097*]	Fe [0.079*] [0.092*]	Co [0.075*] [0.089*]	Ni [0.083]	Cu 0.087 (0.108)	Zn 0.089	Ga 0.076	Ge 0.068	As 0.064	Se (0.043 †)	Br 0.182									
Rb 0.163	Sr 0.1217	Y 0.104	Zr 0.086	Nb 0.078	Mo 0.074	Tc (0.078)	Ru 0.076	Rh 0.0755	Pd (0.100)	Ag (0.129)	Cd 0.109	In 0.094	Sn 0.083 (0.105)	Sb 0.075	Te (0.068)	I 0.206									
Cs 0.184	Ba 0.150	La 0.1185	Hf 0.085	Ta 0.078	W 0.074 (0.079)	Re 0.066	Os 0.077	Ir 0.077	Pt 0.077 (0.092)	Au	Hg 0.116	Tl 0.1025	Pb 0.0915 (0.132)	Bi 0.086 (0.116)	Po	At									

(b)

Figure 2.3 (Continued)

large spherical anions packed in such a way as to fill the space available optimally. Cations fit into positions between the large anions. Large cations tend to be surrounded by a cubic arrangement of anions, medium-sized cations by an octahedral arrangement of anions, and small cations by a tetrahedron of anions. The smallest cations are surrounded by a triangle of anions. Local charge neutrality should occur, as far as possible. These and other ways of looking at ionic structures are described more fully in the sources listed in the Further Reading section at the end of this chapter.

2.2 Covalent bonding

2.2.1 Molecular orbitals

Covalent bonds form when an unpaired electron in an atomic orbital on one atom interacts with an unpaired electron in an atomic orbital on another atom. The electrons, which are initially completely localised on the parent atoms, are now shared between the two, in a molecular orbital. This constitutes a covalent bond. The electrons have become

delocalised. As two electrons are involved, covalent bonds are also called electron-pair bonds. Covalent bonds are strongest when there is maximum overlap between the contributing atomic orbitals. Covalent bonds are, therefore, strongly directional, and covalent bonding successfully explains the geometry of molecules.

An example of the way in which electron sharing comes about can be given by considering the hydrogen molecule, H_2 . An isolated hydrogen atom has a single electron in a spherical $1s$ orbital. As distance between the atoms is reduced, two different kinds of interaction are possible, depending on whether the spins of the electrons in the s orbitals of the two atoms are parallel or opposed. If the spins of the electrons on the two atoms are opposed, as the interatomic distance is reduced both electrons begin to experience attraction from both nuclei. There is also electrostatic repulsion between the two electrons, but the attraction preponderates bonding is said to occur and the nuclei are pulled together. A (covalent) bond forms. It is found that the electron density, which was originally spherically distributed around each atom (Figure 2.4a) is now concentrated between the nuclei (Figure 2.4b). If

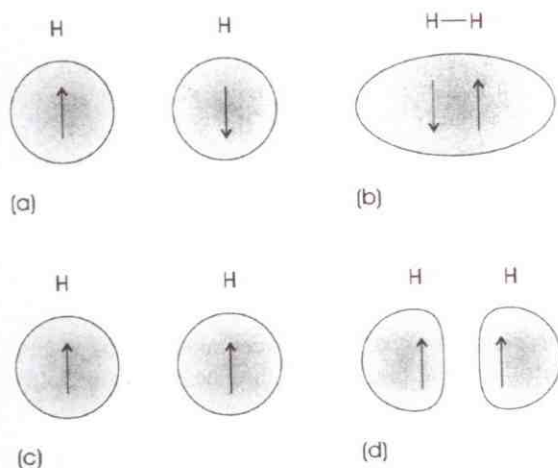

Figure 2.4 Isolated hydrogen atoms have spherically symmetrical 1s orbitals, each containing one s electron, represented as an arrow. Two atoms can have electrons in (a) an antiparallel or (c) parallel arrangement; (b), if the electrons have antiparallel spins the electron density accumulates between the nuclei to form a covalent bond; (d) if the electrons have parallel spins the electron density is low between the nuclei and no bond forms

the spins of the two electrons are parallel, the Pauli exclusion principle stipulates that it is energetically unfavourable for the electron clouds to overlap. The electron density avoids the internuclear region (Figure 2.4d), and bonding does not occur. The consequences of this 'antibonding' alternative are considered further below.

Two p orbitals end-on to each other and each containing a single electron can interact in very much the same way (see Figure 2.5b). The same is true for a combination of half-filled s and end-on p orbitals (Figure 2.5a).

A molecular orbital formed by s orbitals, end-on p orbitals or by s and p orbitals has rotational symmetry about the bond axis, which is the line joining the two nuclei contributing the electrons. As a result, a cross-section through the orbital looks like an s orbital and, in recognition of this symmetry relationship, such molecular orbitals are termed σ orbitals. The bonds formed by σ molecular orbitals are often called σ bonds.

A different type of molecular orbital can be formed between two p orbitals, each with a single

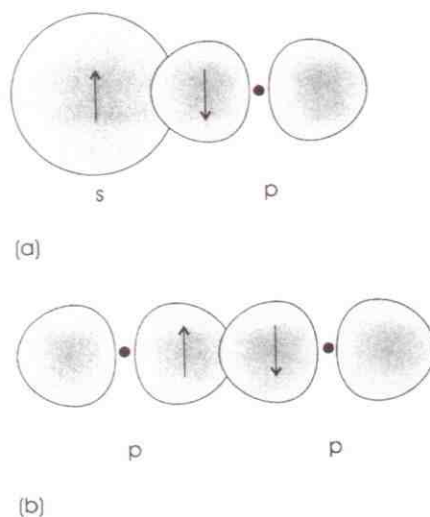

Figure 2.5 A covalent σ bond formed by the overlap of (a) an s orbital and an end-on p orbital when the two electrons have antiparallel spins and (b) two end-on p orbitals when the electrons have antiparallel spins

electron and with opposed spins, approaching each other sideways on (Figure 2.6). In this case, the 'pile-up' of the electron density occurs either side of the nodal plane in which the two nuclei are situated. In this configuration bonding can also occur, but the molecular orbital looks like a p orbital in cross-section, and such molecular orbitals are termed π orbitals. The bonds formed by π molecular orbitals are called π bonds.

It is important to note that the designation of a bond as σ or π does not depend on the type of orbital forming the bond, only the geometry of overlap of the orbitals.

2.2.2 The energies of molecular orbitals in diatomic molecules

In order to be sure that a bond actually forms between two atoms linked by a molecular orbital it is necessary to calculate the energies of the molecular orbitals and then allocate electrons to them. In essence, the approximate Schrödinger equation

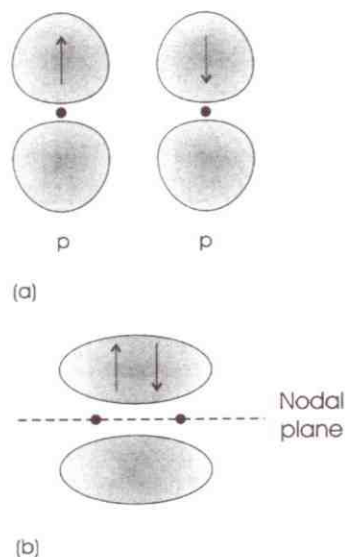

Figure 2.6 (a) Two sideways-on p orbitals containing electrons with antiparallel spins; (b) a π bond formed by the sideways-on overlap of p orbitals. The electron density is concentrated above and below the plane containing the nuclei, and is zero in this plane, called a nodal plane

for the molecule must be solved. This process is similar to the method used for solving the electron configuration of many-electron atoms. An approach called molecular orbital theory is usually chosen for this task. In this, the molecular orbital is obtained by adding together contributions from all of the atomic orbitals involved. This is called the linear combination of atomic orbitals, or LCAO, method. Thus for two identical atoms, each contributing one orbital – say two hydrogen atoms each contributing an s orbital – the molecular orbitals are given by:

$$\psi(\text{molecule}) = c_1 \chi_1 + c_2 \chi_2$$

where c_1 and c_2 are parameters that have to be determined, and χ_1 and χ_2 are the wavefunctions on atom 1 and atom 2. The values of the parameters and the energy of the molecular orbitals are calculated by using standard methods (see the further reading section).

The calculations show that when two atomic orbitals interact, two molecular orbitals form, one with a higher energy than the original pair and one with a lower energy than the original pair. The molecular orbital of lower energy than the parent atomic orbitals is the one with the greatest concentration of electron density between the nuclei (Figure 2.4b). These orbitals are called bonding orbitals. The molecular orbital of higher energy than the parent atomic orbitals is the one in which the electron density is concentrated in the region outside of the line joining the nuclei (Figure 2.4d). Such orbitals are antibonding orbitals.

The energies of the two molecular orbitals are given as follows:

$$E_{\text{bond}} = \alpha + \beta$$

$$E_{\text{abond}} = \alpha - \beta$$

The term α , called the Coulomb integral, is related to the Coulomb energy of the electrons in the field of the atoms and in general is a function of the nuclear charge and the type of orbitals involved in the bond. By definition, the Coulomb energy is regarded as negative. [Note that the Coulomb integral and the Madelung constant, confusingly, both use the same symbol, α ; take care not to equate the two terms.] The term β is called the resonance integral, or interaction integral, and in general is a function of the atomic number of the atoms, the orbital types and the degree of overlap of the orbitals. In the case where electron density 'pile up' between the nuclei, β is negative. Thus, the lower energy bonding orbital corresponds to E_{bond} and the higher energy antibonding orbital corresponds to E_{abond} .

Consider again the situation when two hydrogen atoms interact. The two 1s orbitals give two molecular orbitals, one bonding and one antibonding (Figure 2.7). To stress the links with the atomic orbitals, these are called $\sigma 1s$, which is the bonding orbital, and $\sigma^* 1s$, which is the antibonding orbital. When two hydrogen atoms meet, both electrons will occupy the bonding, $\sigma 1s$, orbital provided that they have opposed spins. This will be the lowest-energy configuration, or ground state, of the pair, and

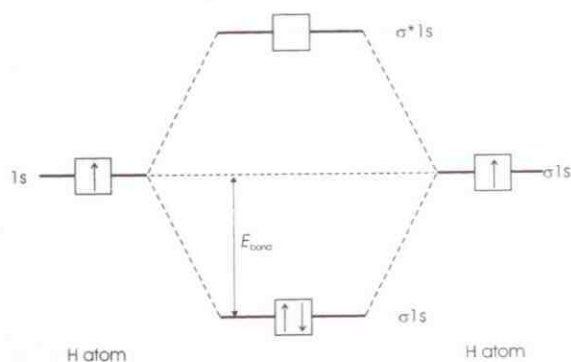

Figure 2.7 The close approach of two hydrogen atoms, each with an electron in a $1s$ orbital, leads to the formation of two molecular orbitals, a bonding $\sigma 1s$ molecular orbital and an antibonding $\sigma^* 1s$ orbital. In the H_2 molecule, both electrons occupy the bonding orbital, and a strong bond with energy $2E_{\text{bond}}$ results

covalently bonded hydrogen molecule, H_2 , will form. The bond energy will be $2E_{\text{bond}}$.

To explain the electron configuration and bonding in other diatomic molecules, the method used to obtain the electron configuration of atoms is copied. Electrons are fed into the available molecular orbitals by using the Aufbau (building-up) principle to obtain the lowest-energy ground state. As before, start at the orbital of lowest energy and work up, feeding two electrons with opposing spin into each orbital and following the Pauli principle and Hund's rules (see Sections 1.3.2 and S1.3.2). This can be illustrated by considering the series of diatomic molecules made up from identical atoms, called homonuclear molecules.

Following hydrogen, the next molecule of this type to consider – singly ionised di-helium, He_2^+ – contains three electrons. The bonding $\sigma 1s$ orbital is full, as a molecular orbital can only contain two electrons of opposed spins, and so the third electron will go into the antibonding orbital $\sigma^* 1s$. Because the energy of this orbital is higher than that of the two isolated atoms, the extra electron will have the effect of partly cancelling the bonding induced by the filled $\sigma 1s$ bonding orbital. We thus expect a weaker and longer bond compared with that of H_2 , but the molecule can be expected to form.

When two helium atoms interact there are four electrons to place in the orbitals and so both the $\sigma 1s$ and the $\sigma^* 1s$ orbitals will be filled. The effect of the filled antibonding orbital completely negates the effect of the filled bonding orbital. No energy is gained by the system and so He_2 does not form.

To derive the electron configurations of the other homonuclear X_2 molecules, formed from the elements of the second period of the periodic table, Li_2 to Ne_2 , exactly the same procedure is followed. That is, electrons from the separate atomic orbitals are allocated to the molecular orbitals from the lowest energy upwards, remembering that the $\sigma 1s$ and $\sigma^* 1s$ orbitals are filled and constitute an unreactive core. The interaction of the $2s$ outer orbitals will form $\sigma 2s$ and $\sigma^* 2s$ orbitals. In addition, the $2p$ orbitals can overlap to form molecular orbitals. End-on overlap, as drawn in Figure 2.5(b), produces $\sigma 2p_x$ and $\sigma^* 2p_x$ molecular orbitals. The sideways on overlap of a pair of p orbitals, as in Figure 2.6, forms one $\pi 2p_y$ bonding orbital, one $\pi 2p_z$ bonding orbital, one $\pi^* 2p_y$ antibonding orbital and one $\pi^* 2p_z$ antibonding orbital. The energy of the orbitals is sketched in Figure 2.8(a) for molecules as far as dinitrogen, N_2 . The difference in energy between the $\sigma 2p_x$ and $\pi 2p$ orbitals is small and gradually changes along the series, so that the $\sigma 2p_x$ orbital drops below the $\pi 2p$ orbitals for the last three molecules – O_2 , F_2 and the hypothetical Ne_2 – drawn in Figure 2.8(b).

The molecular configurations of the homonuclear diatomic molecules can now be obtained by using the Aufbau principle. The first to consider is dilithium Li_2 . The electron configuration of lithium, (Li), is $[He]2s^1$. Both $2s$ electrons will occupy the lowest available bonding orbital, and a stable molecule will form. The next element, beryllium, (Be), has an electron configuration $[He] 2s^2$. An attempt to form the molecule Be_2 will necessitate placing two electrons in the bonding orbital and two in the lowest available antibonding orbital. No stable molecule will form. The next atom, boron, (B), has an electron configuration $[He] 2s^2 2p^1$, and electrons now enter the bonding $\pi 2p$ orbitals. The repetitive filling continues with the other elements, with the result given in Table 2.3.

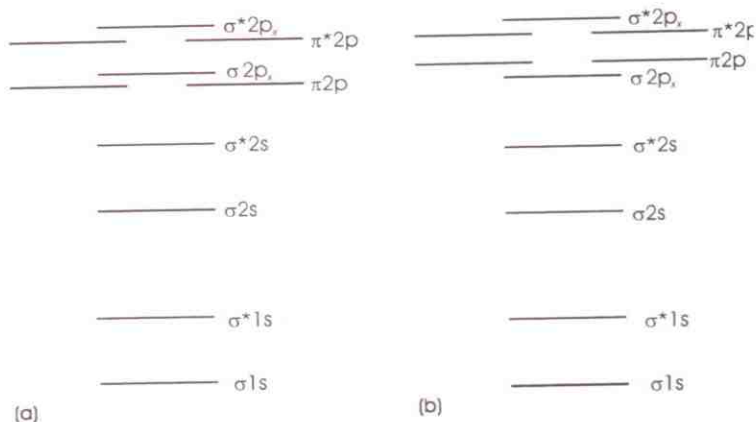

Figure 2.8 (a) Schematic molecular orbital energy level diagram for homonuclear diatomic molecules H_2 to N_2 ; (b) schematic energy level diagram for the homonuclear diatomic molecules O_2 to Ne_2

Table 2.3 The electron configurations of some homonuclear diatomic molecules

Molecule	Ground-state configuration	Bond length/nm	Bond energy/kJ mol ⁻¹
Li_2	$[He_2](\sigma 2s)^2$	0.267	101
Be_2	$[He_2](\sigma 2s)^2(\sigma^* 2s)^2$	—	—
B_2	$[Be_2](\pi 2p)^2$	0.159	289
C_2	$[Be_2](\pi 2p)^4$	0.124	599
N_2	$[Be_2](\pi 2p)^4(\sigma 2p_x)^2$	0.110	941
O_2	$[Be_2](\pi 2p)^4(\sigma 2p_x)^2(\pi^* 2p)^2$	0.121	494
F_2	$[Be_2](\pi 2p)^4(\sigma 2p_x)^2(\pi^* 2p)^4$	0.142	154
Ne_2	$[Be_2](\pi 2p)^4(\sigma 2p_x)^2(\pi^* 2p)^4(\sigma^* 2p_x)^2$	—	—

— Molecule is not formed.

Note: $[He_2] = (\sigma 1s)^2(\sigma^* 1s)^2$; $[Be_2] = (1\sigma)^2(1\sigma^*)^2(2\sigma)^2(2\sigma^*)^2$.

An important verification of the molecular orbital theory was provided by the oxygen molecule, O_2 . This molecule had long been known to be paramagnetic; a puzzling property. However, the electron configuration given in Table 2.3 shows that the two electrons with highest energy have to be placed in separate orbitals (Figure 2.9). These unpaired electrons make the molecule paramagnetic (see Chapter 12).

2.2.3 Bonding between unlike atoms

When a molecular orbital, whether of σ or π type, is formed between atoms of two different elements, A

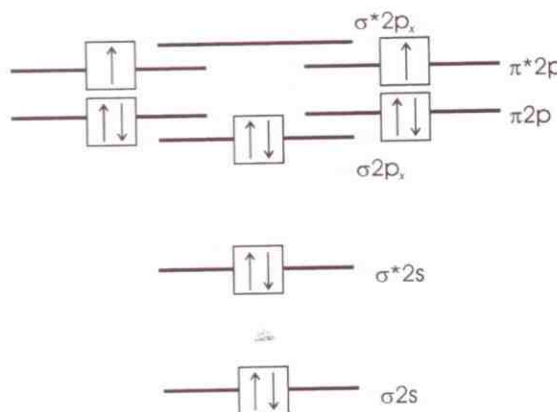

Figure 2.9 The ground-state electron configuration of O_2 . Each oxygen atom contributes eight electrons, and each orbital up to the $\pi 2p$ set contains paired electrons. The last two electrons occupy separate $\pi^* 2p$ orbitals, with parallel spins.

and X, then the energy levels of the initial atomic orbitals will differ, as will their extensions in space. One can construct an appropriate molecular orbital energy diagram for this situation, as in Figure 2.10. This corresponds to the case where element A is more metallic (or less electronegative, see p. 35) than element X. The bonding energy E_b is now with respect to the average energy of the uninteracting A and X atoms: $\frac{1}{2}(E_A + E_X)$. It is found that the X atom contributes most to the bonding molecular orbital, and the atom A most to the antibonding molecular orbital. The bond is

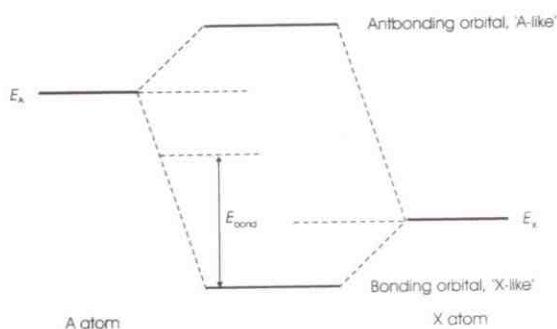

Figure 2.10 Molecular orbitals formed by a more metallic atom A and a less metallic atom X. The non-metallic element contributes more to the bonding orbital, which is said to be X-like. The more metallic atom contributes more to the antibonding orbital, which is said to be A-like

molecular orbitals are often said to be 'X-like' in character, and the antibonding orbitals 'A-like' in character.

A bonding molecular orbital concentrates electronic charge density in the region between the bonded nuclei (subject, in the case of π bonding, to the limitation set by the nodal plane). If the two nuclei are different, they will have different effective nuclear charges. This will cause the concentration of charge to shift to increase the screening of the higher effective charge and decrease that of lower effective charge, until both have become equalised. Therefore, the symmetrical build up of electron density shown in Figures 2.4 and 2.6 will become modified to that in Figure 2.11.

Obviously with a very large difference in effective nuclear charge, one would have something approaching ions being formed, both electrons of the molecular orbital becoming almost completely associated with the X atom, giving it nearly unit negative charge, whereas the A atom would have almost unit positive charge.

A covalent bond in which the electron pair is distributed unevenly is sometimes called a polar covalent bond. The bond will have one end that carries a small positive charge, written $\delta+$, and the other end a small negative charge, $\delta-$. The charge separation gives rise to an internal electric dipole (Figure 2.11) and such molecules are called polar

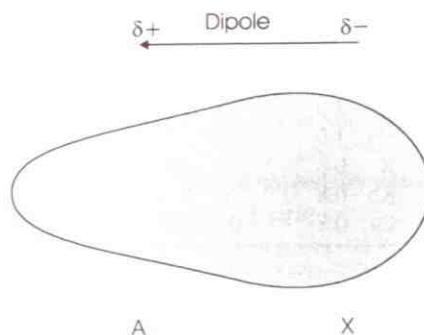

Figure 2.11 The electron density in a bonding molecular orbital between two dissimilar atoms is distorted so that the end nearer to the nonmetallic atom attracts more of the charge cloud. The bond is then an electric dipole, with charges $\delta+$ and $\delta-$, represented by an arrow pointing from the negative to the positive charge

molecules. An electric dipole is a vector quantity and is drawn as an arrow pointing from the negative charge to the positive.

A polyatomic molecule may contain a number of polar covalent bonds. For example, water (H_2O) is a polar molecule as the two O—H bonds form dipoles pointing towards the hydrogen atoms. However, not all molecules containing several dipoles are polar, as the dipoles within the molecule, the internal dipoles, may sum to zero.

2.2.4 Electronegativity

The idea of atoms possessing a tendency to attract electrons is rather useful, and the electronegativity, χ , of an element represents a measure of its power to attract electrons during chemical bonding. Atoms with a low electronegativity are called electropositive elements. These are the metals, and when bonded they do not have a strong tendency to attract electrons and so tend to form cations. Atoms with a high electronegativity, called electronegative elements, tend to attract electrons in a chemical bond and tend to form anions. The magnitude of the partial charges, $\delta+$, $\delta-$, in a polar molecule is dependent on the electronegativity difference between the two atoms involved.

Table 2.4 Electronegativity values

H	2.2												
Li	1.0	Be	1.5	B	2.0	C	2.5	N	3.0	O	3.5	F	4.0
Na	1.0	Mg	1.2	Al	1.5	Si	1.8	P	2.1	S	2.5	Cl	3.0
K	0.8	Ca	1.0	Ga	1.5	Ge	1.8	As	2.0	Se	2.4	Br	2.8
Rb	0.8	Sr	1.0	In	1.5	Sn	1.8	Sb	1.8	Te	2.1	I	2.5
Cs	0.8	Ba	0.9	Tl	1.5	Pb	1.7	Bi	1.8				

Source: adapted from selected values of Gordy and Thomas, taken from W. B. Pearson, 1972, *The Crystal Chemistry and Physics of Metals and Alloys*, Wiley-Interscience.

Electronegativity values have been derived in a number of ways. The first of these was by Pauling and made use of thermochemical data to obtain a scale of relative values for elements. Most electronegativity tables since then have also contained relative values, which do not have units.

In general, the most electronegative atoms are those on the right-hand side of the periodic table, typified by the halogens fluorine and chlorine (Table 2.4). The least electronegative atoms, which are the most electropositive, are those on the lower left-hand side of the periodic table, such as rubidium, Rb, and caesium, Cs (Table 2.4). Covalent bonds between strongly electronegative and strongly electropositive atoms would be expected to be polar.

2.2.5 Bond strength and direction

So far, the energetic aspects of covalent bonds have been considered by using molecular orbital theory. Molecular orbital theory is equally well able to give exact information about the geometry of molecules. However, a more intuitive understanding of the geometry of covalent bonds can be obtained via an approach called valence bond theory. (Note that both molecular orbital theory and valence bond theory are formally similar from a quantum mechanical point of view, and either leads to the same result.)

Valence bond theory starts with the idea that a covalent bond consists of a pair of electrons shared between the bound atoms. Two resulting ideas make it easy to picture covalent bonds. The first of these is the concept that the direction of a bond will be such as to make the orbitals of the bonding electrons

overlap as much as possible. The second is that the strongest bonds are formed when the overlapping of the orbitals is at a maximum. On this basis, we expect differences in bond-forming power for s, p, d and f orbitals since these orbitals have different radial distributions. The relative scales of extension for 2s and 2p orbitals are 1 and $\sqrt{3}$ respectively (Figure 2.12). The shapes of the p orbitals leads to the expectation that p orbitals should be able to overlap other orbitals better than s orbitals and hence that bonds involving p orbitals should generally be stronger than bonds involving s orbitals. If there is a choice between s or p orbitals, use of p orbitals should lead to more stable compounds.

The geometry of many molecules can be qualitatively explained by these simple ideas. Consider the bonding in a molecule such as hydrogen chloride, HCl. The hydrogen atom will bond via its s orbital end on to the one half-filled p orbital on the chlorine atom. The hydrogen nucleus will lie along the axis of the 2p orbital since this gives the maximum overlap for a given internuclear spacing (Figure 2.13). Consider the situation in a water molecule,

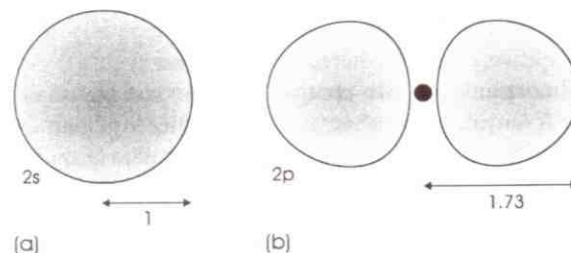

Figure 2.12 The relative extension of (a) a 2s orbital (1.0) and (b) a 2p orbital ($\sqrt{3}$, 1.73)

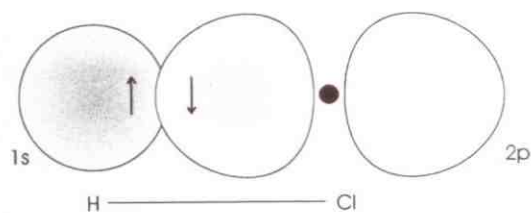

Figure 2.13 The covalent bond in a linear molecule such as hydrogen chloride (HCl) is formed by the overlap of a 1s orbital on the hydrogen atom with the $2p_x$ orbital on the chlorine atom. The electron spins in each orbital must be antiparallel for a bond to form

H_2O . The two hydrogen atoms form bonds with two different half-filled p orbitals on the oxygen atom. As these lie at 90° to each other, the molecule should be angular, with an H—O—H angle of 90° . Similarly, the molecule of ammonia, NH_3 , involves bonding of the hydrogen 1s orbitals to the three 2p orbitals that lie along the three Cartesian axes. The shape of the molecule should mimic this, with the three hydrogen atoms arranged along the three Cartesian axes, to form a molecule that resembles a flattened tetrahedron. To a rough approximation, these molecular shapes are correct, but they are not precise enough. For example, the actual H—O—H angle is 104.5° , considerably larger than 90° . To explain the discrepancy it is necessary to turn to a more sophisticated concept.

2.2.6 Orbital hybridisation

Although water and ammonia provide examples of the disagreement between the simple ideas of orbital overlap and molecular geometry, the most glaring example is provided by carbon. From what has been said so far, one would expect carbon, with an electron configuration of $1s^2 2s^2 2p^2$, to form compounds with two p bonds at 90° to one another. That is to say, in reaction with hydrogen, following the same procedure as above, a molecule of formula CH_2 should form and have the same 90° geometry as water. Now the common valence of carbon is four and, as early as the latter half of the 19th century, organic chemists established beyond doubt that in

the small molecules formed by carbon the four bonds are directed away from the carbon atom towards the corners of a tetrahedron. The orbital picture so far presented clearly breaks down when applied to carbon. This discrepancy between theory and experiment has been resolved by introducing the concept of orbital hybridisation.

Hybridisation involves combining orbitals in such a way that they can make stronger bonds (with greater overlap) than the atomic orbitals depicted earlier. To illustrate this, suppose that we have one s and one p orbital available on an atom (Figure 2.14a). These could form two bonds, but neither orbital can utilise all of its overlapping ability when another atom approaches. However, an s and a p orbital can combine, or *hybridise*, to produce two new orbitals pointing in opposite directions, (Figure 2.14b). Each resulting hybrid orbital is composed of one large lobe and one very small lobe, which can be thought of as the positive s orbital adding to the positive lobe of the p orbital to produce a large lobe, and the positive s orbital adding to the negative lobe of the p orbital to produce a small lobe.

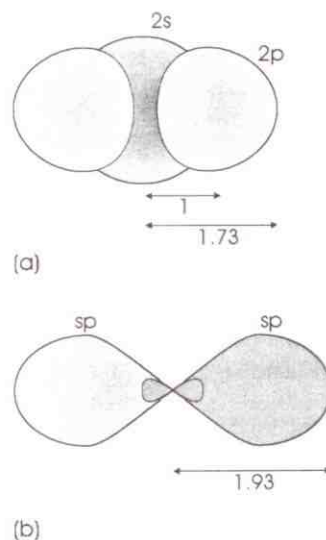

Figure 2.14 (a) The $2s$ and $2p_x$ orbitals on an atom and (b) the two sp hybrid orbitals formed by combining the $2s$ and $2p_x$ orbitals. Each hybrid orbital has a large lobe and a small lobe. The extension of the large lobe is 1.93, compared with 1.0 for a $2s$ orbital and 1.73 for a $2p_x$ orbital. The orbitals point directly away from each other

of the p orbital to give a small lobe. The overlapping power of the new combination is found to be significantly larger than that of s or p orbitals, because the extension of the hybrid orbitals is 1.93, compared with 1.0 for an s orbital and 1.73 for a p orbital. Although it requires energy to form the hybrid configuration, this is more than recouped by the stronger bonding that results, as discussed in more detail below with respect to the tetrahedral bonding of carbon. Since the hybrid orbitals are a combination of one s and one p orbital, they are called sp hybrid orbitals. The large lobe on each of the hybrid orbitals can be used for bond formation, and bond angles of 180° are expected.

The idea can be illustrated with the atom mercury, Hg. The outer electron configuration of mercury is $6s^2$. The filled electron shell would not be able to form a bond at all. However, the outer orbital energies are very close in these heavy atoms, and little energy is required to promote an electron from the 6s orbital to one of the 6p orbitals. In this configuration, the orbitals can combine to form two sp hybrid orbitals. Mercury makes use of sp hybrid bonds in the molecule $(\text{CH}_3)_2\text{Hg}$. In this molecule, the Hg forms two covalent bonds with carbon atoms. The C–Hg–C angle is 180° . The strong bonds that can then form more than repay the energy expenditure involved in hybridisation. The linear geometry of sp hybrid bonds is further illustrated with respect to bonding in a molecule of ethyne (acetylene, C_2H_2), described below.

It is a general rule of hybrid bond formation that the same number of hybrid orbitals form and can be used for bonding as the number of atomic orbitals used in the initial combination. Thus, one s and one p orbital yield two sp hybrid orbitals. One s orbital and two p orbitals yield three new sp^2 hybrid orbitals for bond formation. For maximum overlap we expect these orbitals to point as far away from each other as possible, so forming bonds at angles of 120° (Figure 2.15). The sp^2 hybrid orbitals have an overlapping power of about twice that of s orbitals. This type of bonding is found in a number of trivalent compounds of boron, for example BCl_3 , which has bond angles of 120° . It is also commonly encountered in borosilicate glasses, in which the boron atoms are linked to three oxygen atoms at the

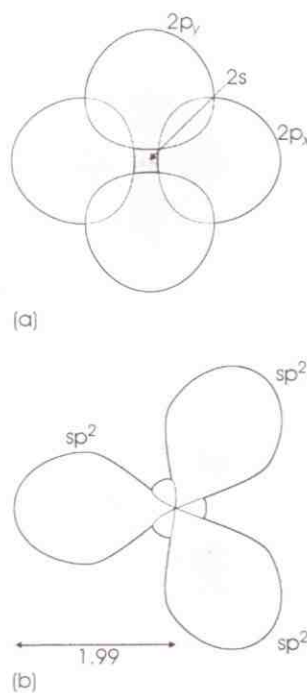

Figure 2.15 (a) The 2s, 2p_x and 2p_y orbitals on an atom and (b) the three sp^2 hybrid orbitals formed by combining the three original orbitals. Each hybrid orbital has a large lobe and a small lobe. The extension of the large lobe is 1.99, compared with 1.0 for a 2s orbital and 1.73 for a 2p_x orbital. The orbitals are arranged at an angle of 120° to each other and point towards the vertices of an equilateral triangle

corners of an equilateral triangle by sp^2 hybrid bonding orbitals.

It is now possible to return to the case of carbon. As mentioned above, it is certain that carbon forms four bonds in many of its compounds. The outer electron configuration of carbon is $2s^2 2p^2$. If one electron is promoted from the filled $2s^2$ orbital into the empty p orbital, sp^3 hybrid orbitals are possible. Calculation shows that the resulting four bonds will point towards the corners of a tetrahedron, at angles of 109° to each other (Figure 2.16). These angles are the tetrahedral angles found for methane, CH_4 , carbon tetrachloride, CCl_4 and many other carbon compounds.

The hybrid orbitals have an overlapping power of twice the overlapping power of s orbitals. Therefore,

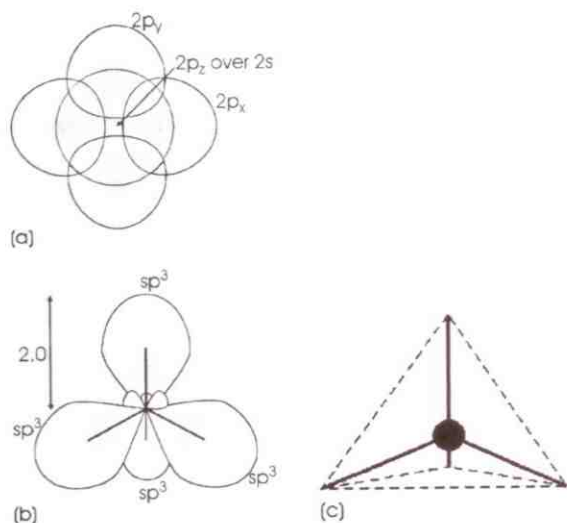

Figure 2.16 (a) The $2s$, $2p_x$, $2p_y$ and $2p_z$ orbitals on an atom; (b) the four sp^3 hybrid orbitals formed by combining the four original orbitals. Each hybrid orbital has a large lobe and a small lobe. The extension of the large lobe is 2.0, compared with 1.0 for a $2s$ orbital and 1.73 for a $2p_x$ orbital. (c) The orbitals are at an angle of 109.5° to each other and point towards the vertices of a tetrahedron

the bonds formed by sp^3 hybrid orbitals are extremely strong. The C–C bond energy in diamond, the hardest of all solids, is 245 kJ mol^{-1} . For these orbitals to form, one electron must be promoted from the filled $2s$ orbital to the empty $2p$ orbital. The energy of the latter process is approximately 400 kJ for the change $1s^2 2s^2 2p^2$ to $1s^2 2s 2p^3$. This is an energetic process, but the energy loss is more than made up by the greater overlap achieved, the stronger bonds that result and, importantly, the number of bonds that form with the rearranged orbitals. For example, carbon, with an electron configuration $2s^2 2p_x 2p_y$, might form two p bonds of perhaps 335 kJ each to hydrogen atoms, which would liberate perhaps 670 kJ, whereas four sp^3 bonds of 430 kJ each would liberate 1725 kJ. The energy of the latter process is clearly sufficient to accommodate the electron promotion energy.

Hybridization explains the geometry of ammonia (NH_3) and water (H_2O) and similar compounds.

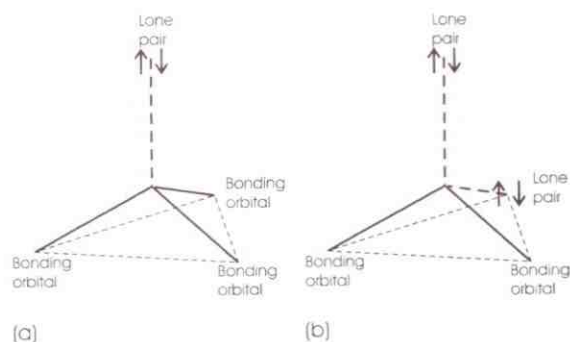

Figure 2.17 The sp^3 hybrid bonds in (a) nitrogen and (b) oxygen. In part (a), three bonds form (full lines), as in NH_3 , and in part (b), two bonds, form (full lines), as in H_2O . The remaining orbitals are filled with electron pairs, called lone pairs

Nitrogen has an outer electron configuration of $2s^2 2p^3$, and oxygen has an outer electron configuration of $2s^2 2p^4$. Although bonding to three or two atoms, respectively, is possible, using the available p orbitals, as described above, stronger bonds result if hybridisation occurs. In both atoms, the s and p orbitals form sp^3 hybrids. In the case of nitrogen (Figure 2.17a) there are five electrons to be allocated. Three of these go into separate sp^3 hybrid orbitals and form three partly filled orbitals. These can be used for bonding, as in NH_3 . The other two electrons fill the remaining orbital. This cannot be used for bonding as it is filled and is said to contain a lone pair of electrons. These lone-pair electrons add significant physical and chemical properties to the ammonia molecule.

A similar situation holds for water. There are now six electrons on the oxygen atom to allocate to the four sp^3 orbitals. In this case, two orbitals are filled, and accommodate lone pairs of electrons, and two remain available for bonding (Figure 2.17b). The two lone pairs occupy two corners of the tetrahedron, and the two bonding orbitals point to the other corners of the tetrahedron. The H–O–H bonding angle should now be the tetrahedral angle, 109° . As in the case of ammonia, the lone pairs contribute significant physical and chemical properties to the molecules. The geometry of the molecules is not quite tetrahedral. The H–O–H angle is 104.5° and

Table 2.5 The geometry of some hybrid orbitals

Coordination number	Orbital configuration	Geometry	Example
2	sp	Linear	HgCl ₂
3	sp ²	Trigonal	BCl ₃
4	sp ³	Tetrahedral	CH ₄
	dsp ²	Square planar	PdCl ₂
6	d ² sp ³	Octahedral	SF ₆

not 109°. Qualitatively, it is possible to say that the presence of the lone pairs distorts the perfect tetrahedral geometry of the hybrid orbitals. Quantitatively, it indicates that the hybridisation model needs further modification.

Hybridisation is not a special effect in which precise participation by, for example, one s and three p orbitals produces four sp³ hybrid orbitals. Continuous variability is possible. The extent to which hybridisation occurs depends on the energy separation of the initial s and p orbitals. The closer they are energetically, the more complete will be the hybridisation. Hybridisation can also occur with d and f orbitals. Hybridisation is no more than a convenient way of viewing the manner in which the electron orbitals interact during chemical bonding. The shape of various hybrid orbitals is given in Table 2.5.

2.2.7 Multiple bonds

In the previous discussion, it was taken for granted that only one bond forms between the two atoms involved. However, one of the most characteristic features of covalent compounds is the presence of multiple bonds between atoms. Multiple bonds result when atoms link via σ and π bonds at the same time.

Multiple bonding occurs in the nitrogen molecule, N₂. Traditionally, nitrogen is described as trivalent, and the molecule is depicted as N≡N, with three bonds linking the two atoms to each other. This is explained in the following way. The outer electron configuration of nitrogen is 2s²2p³. Instead of

forming hybrid orbitals, the three p orbitals on each nitrogen atom can interact to create three bonds. As two nitrogen atoms approach each other, one pair of these p orbitals, say the p_x orbitals, combine in an end-on fashion, to form a σ bond. The other two p orbitals, p_y and p_z, can overlap in a sideways manner to form two π bonds. Each individual π bond has two lobes, one lobe to one side of the internuclear axis and one lobe to the other. The two π bonds comprise four lobes altogether, surrounding the internuclear axis (Figure 2.18). Note that the traditional representation of three bonds drawn as lines N≡N, does not make it clear that two different bond types exist in N₂.

In the case of the oxygen molecule, O₂, conventionally written O=O, a similar state of affairs is found. Oxygen atoms are regarded as divalent, and the molecule consists of two oxygen atoms linked by a double bond. The outer electron configuration of oxygen is 2s² 2p⁴. One p orbital will be filled with an electron pair and takes no part in bonding. Only the two p orbitals, p_x and p_y, are available for bonding. Close approach of two oxygen atoms will allow the p_x orbitals to overlap end on to form a σ bond and the p_y orbitals to overlap in a sideways fashion to form a π bond (Figure 2.19). As with nitrogen, the conventional representation of the double bond, O=O, does not reveal that two different bond types are present.

Multiple bonding is of considerable importance in carbon compounds and figure prominently in the chemical and physical properties of polymers. Two compounds need to be examined, ethyne (acetylene, C₂H₂) and ethene (ethylene, C₂H₄).

The organic compound ethyne, C₂H₂, combines hybridisation with multiple bond formation. The formula is conventionally drawn as HC≡CH, in which three bonds from each quadrivalent carbon atom link to another carbon atom and the other bond links to hydrogen. Because there are two p electrons available on carbon it would be possible to write down a bonding scheme involving only σ bonds one between the two carbons and one between a carbon and a hydrogen atom. However, this is not in accord with the properties of the molecule. First, the carbon atom so described would be divalent not quadrivalent. Second, experiments show that the

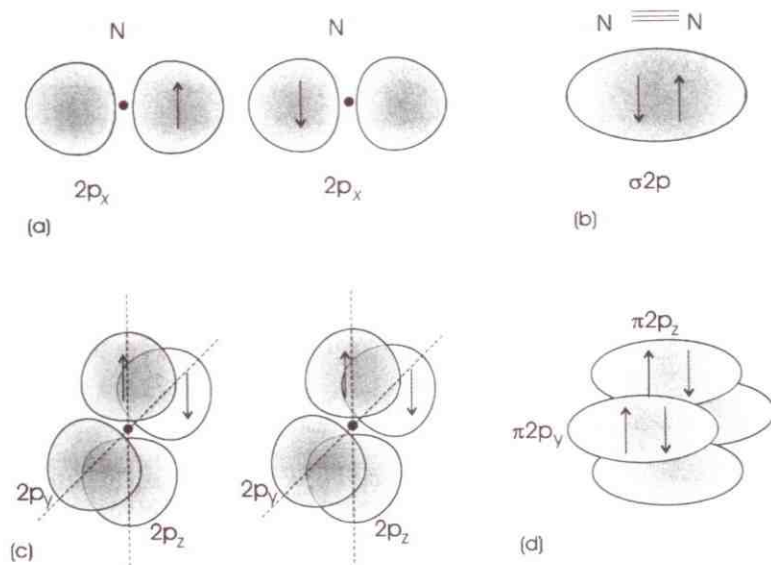

Figure 2.18 Bonding in N_2 ; each nitrogen atom has an unpaired electron in each of the three $2p$ orbitals. Overlap of the $2p_x$ orbitals, (part a) results in a σ bond (part b). Overlap of the $2p_y$ and $2p_z$ orbitals (part c) results in the formation of two π bonds (part d). The conventional representation of a triple bond, $N \equiv N$, does not convey the information that there are two different bond types

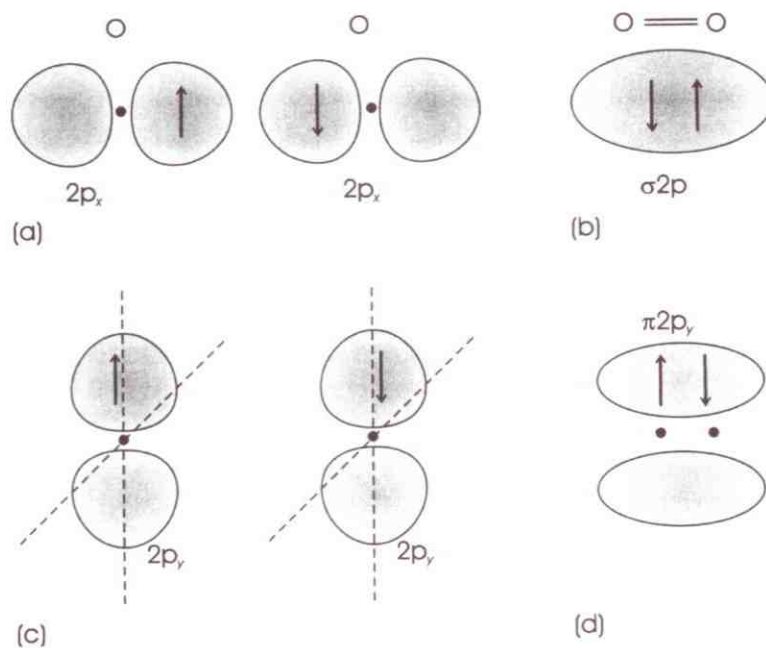

Figure 2.19 Bonding in O_2 ; each oxygen atom has an unpaired electron in two of the three $2p$ orbitals. Overlap of the $2p_x$ orbitals (part a) results in a σ bond (part b). Overlap of the $2p_y$ orbitals (part c) results in the formation of a π bond (part d). The conventional representation of a double bond, $O = O$, does not convey the information that there are two different bond types

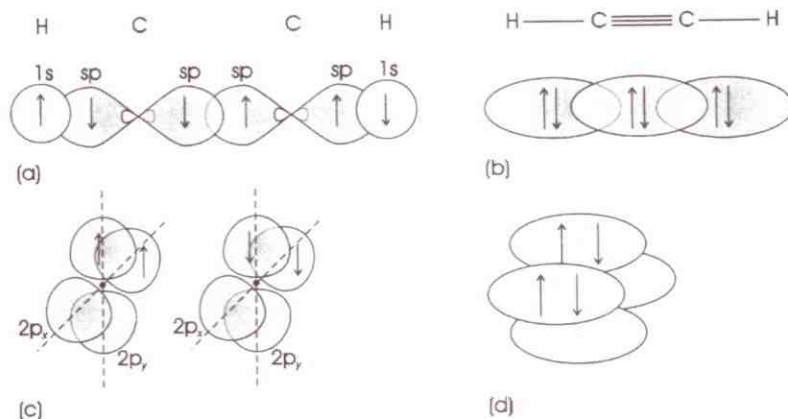

Figure 2.20 Bonding in ethyne (acetylene), C_2H_2 . Overlap of the $1s$ orbitals of H with the sp hybrid orbitals on C (part a) results in a σ bonded molecule (part b). Overlap of the $2p_y$ and $2p_z$ orbitals on C (part c) results in the formation of two π bonds (part d). The conventional representation of the triple bond as $C\equiv C$, does not convey the information that there are two different bond types

carbon – carbon bond in ethyne is much stronger than a normal single carbon – carbon σ bond. Third, the $H - C - C - H$ angles are not 90° , as they would be in the simple picture, but are 180° , and the molecule is linear (Figure 2.20a). The bonding in this molecule is best treated in terms of hybridisation. As described above, the $2s^2 2p^2$ configuration of carbon is changed to $2s^2 2p^3$ by promotion of one of the s electrons to a p orbital. The next stage is the formation of a pair of sp hybrid orbitals, using up the s orbital and the p_x orbital. These form the linear molecular skeleton, joined by σ bonds (Figure 2.20b). The p_y and p_z orbitals on the carbon atoms each hold one electron. These can overlap sideways on, exactly as in the N_2 molecule, to form two π bonds, and complete the triple bond (Figure 2.20c,d).

The physical and chemical properties of ethene, C_2H_4 , drawn in a conventional fashion in Figure 2.21, are not well explained by models involving only σ bonds. Instead, the $2s^2 2p^2$ configuration of carbon is changed to $2s^2 2p^3$ by promotion of one of the s electrons to a p orbital. In the next step, sp^2 hybrid orbitals form on each carbon atom, leaving one unpaired electron in the unaltered p_z orbital. The three sp^2 hybrid orbitals on each carbon atom lie at angles of 120° to each other. These are used to

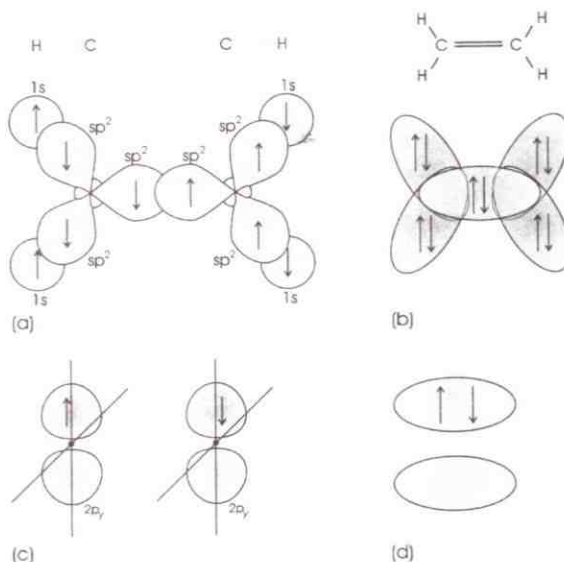

Figure 2.21 Bonding in ethene (ethylene), C_2H_4 . Overlap of the $1s$ orbitals of H with the sp^2 hybrid orbitals on C (part a) results in a σ bonded molecule (part b). Overlap of the $2p_z$ orbitals on C (part c), results in the formation of a π bonds (part d). The conventional representation of the double bond as $C=C$, does not convey the information that there are two different bond types

bond to two hydrogen atoms and one carbon atom in a triangular arrangement, to form the σ bonded skeleton of the molecule (Figure 2.21a,b). The observed value for the H-C-H angles of ethylene is 117° , which is close to the 120° value for sp^2 bonds. The remaining p_z orbital on the two carbon atoms overlaps sideways on to form a π bond (Figure 2.21c,d).

The exposed electrons in the π bonds contribute significantly to the properties of the molecules. In particular, they endow them with a high refractive index and high chemical reactivity.

2.2.8 Resonance

The bonding in molecules containing multiple bonds can often be drawn in a number of alternative ways. The classical example of this is the molecule benzene, C_6H_6 . The two conventional ways of representing the scheme of bonding in this molecule are drawn in Figure 2.22(a). The molecule is planar, the carbon atoms are arranged in a perfect hexagon and the hydrogen atoms, one attached to each carbon, are omitted. The properties of benzene are best explained if the bonding is considered to be a blend of the two schemes (as well as of other more energetic structures not shown). The resultant is called a resonance hybrid, often drawn as in Figure 2.22(b), for the reason given below.

The bonding that can give rise to this is closely related to that in ethene. Each carbon atom forms sp^2 hybrids, and six carbon atoms link together and to six hydrogen atoms to produce the σ bond skeleton of the hexagonal molecule (Figure 2.22c). The remaining p_z orbitals, one on each carbon atom, overlap sideways on to form π bonds with lobes that extend above and below each of the carbon atoms in the plane of the hexagon (Figures 2.22d and 2.22e).

In this concept, the skeleton of σ bonds is invariant. These bonds, (like each of the others that have been discussed above) are said to be localised, which means that they are limited to the region between two atoms. Unlike the σ bonds, the π bonds spread out between all of the contributing atoms, to give delocalised orbitals, and are not restricted to lie between pairs of atoms. To indicate that the bonding

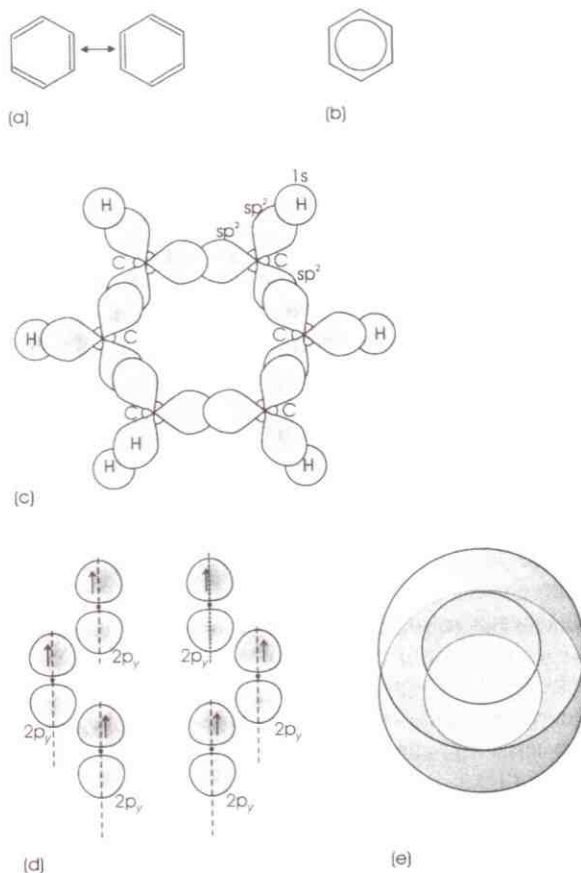

Figure 2.22 Bonding in benzene, C_6H_6 . (a) Conventional bonding diagrams for the two main alternative resonance hybrid structures of the benzene molecule. The lines indicate bonds between carbon atoms, which lie at the vertices of a hexagon. Each carbon is linked to one hydrogen atom (omitted) and two carbon atoms. (b) The benzene molecule is often drawn as a hexagon enclosing a circle, to indicate the resonance nature of the bonding. The bonding is more complicated than the conventional diagrams indicate. Overlap of the $1s$ orbitals of H with the sp^2 hybrid orbitals on C (part c) results in a σ bonded hexagonal molecule. Overlap of the $2p_y$ orbitals on C (part d), results in the formation of π bonds (part e). The lobes of the π bonds lie above and below the plane of the C-H planar structure, and delocalisation means that the orbitals are spread equally over the ring. The representation of the molecule in part (b) attempts to convey some of this information

in a molecule such as benzene is a superposition of localised and delocalised bonding schemes, it is often represented as in Figure 2.22(b), where the hexagon represents the σ bond skeleton of the molecule and the circle drawn within the hexagon represents the delocalised π bonds. Often it is convenient to use localised bond representations of the structures contributing to resonance hybrids. The fact that the real situation is one of resonance is indicated by the use of double-headed arrows, \leftrightarrow , between the resonance hybrid structures (Figure 2.22a). (Note that these are not the only resonance hybrid structures that can be drawn for benzene, only the two that contribute most to the stability of the molecule.)

There is a distinction between resonance hybrids and hybrid orbitals. Resonance hybrids are the result of blending the bonding in molecules (or fragments of molecules) to give a bonding picture that better mirrors the chemical and physical properties of the molecules. Hybrid orbitals are a blend of orbitals on a single atom. Resonance is found in inorganic and organic molecules and is often revealed by intense colour or unusual electronic properties.

2.3 Metallic bonding

2.3.1 Bonding in metals

Ionic and covalent bonds are theories of chemical valence. A theory of metallic bonding has not only to explain this aspect of the linking of atoms but also typically 'metallic' properties. Metallic bonds must possess the following characteristics. The bonds act between identical and different metallic atoms, as is revealed by the formation of numerous alloy structures as well as the structures of the elements. The bonds act between many atoms, as metal atoms in crystals often have either 8 or 12 neighbours. The bonds are maintained in the liquid state, as liquid metals retain the distinguishing properties of crystalline metals. The bonds must permit easy electron transfer throughout the structure. In addition, the theory should account for the

fact that the majority of the elements in the periodic table are metals.

The present-day understanding of metals and metallic bonding has arisen from a combination of two different approaches. In the first of these electrons travel more or less freely through the structure. Formally, this is called free-electron theory. A second approach, more chemical in nature considers metallic bonds as a spreading out or delocalisation of covalent bonds. This delocalisation was mentioned in Section 2.2.8 with respect to the orbitals of benzene, which extend over the whole molecule. In metals, the delocalisation is thought to extend throughout the solid. Formally, this is called the tight-binding theory. To understand metallic materials in the broadest sense, a combination of both approaches must be used. Moreover, accurate calculations use more sophisticated models than either the free-electron or the tight-binding approach. The application of these ideas, called band theory, successfully explains the detailed physical properties of metals.

The chemical approach is considered initially. Free-electron theory is discussed in Sections 2.3 and 2.3.6, and an account of the important electronic properties of solids is postponed to Chapter 13.

2.3.2 Chemical bonding

From the point of view of the molecular orbital model of chemical bonding, when two atoms approach each other the outer electrons interact and atomic orbitals become extended over both nuclei to form molecular orbitals. When two similar atomic orbitals interact, one on each atom, two molecular orbitals form, one of lower energy than either of the atomic orbitals, the bonding orbital and one of higher energy, the antibonding orbital (Figure 2.23). The same principle has been found to apply no matter how many atoms are involved. Instead of two atoms, there are three, three orbitals form. One will be a lower-energy bonding orbital, one a higher-energy antibonding orbital and one will have the same energy as the original atomic orbitals and is called a nonbonding orbital. W

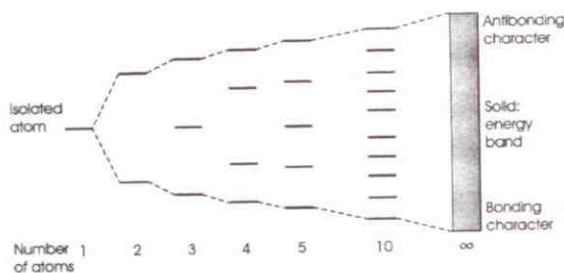

Figure 2.23 The development of an energy band from delocalised molecular orbitals. Each atom in the molecule contributes one molecular orbital. An isolated atom has sharp energy levels (left-hand side). As the number of atoms increases, the number of discrete orbitals merges into a band of closely spaced energy levels (right-hand side)

four atoms, each contributing one atomic orbital, four molecular orbitals, two of higher-energy antibonding orbitals and two of lower-energy bonding orbitals, are produced. If there are N atoms in the solid, each contributing one atomic orbital, N molecular orbitals will form, half at lower energies and half at higher energies.

There is an important point that emerges from energy calculations. The separation between the highest-energy and the lowest-energy rapidly becomes constant as the number of atoms in the solid increases. However, as the number of energy levels that have to fit into this energy space is equal to the number of atoms in the solid, the energy levels get closer together. When a large number of atoms are included, it is simpler to say that an energy band has been created, as illustrated on the far right-hand side of Figure 2.23. Within the energy band, the energy levels are so closely spaced that it is not too bad an approximation to think that a continuum of energies is found. The upper part of the band will correspond to antibonding orbitals and is said to have an antibonding character. The lower part of the band will correspond to bonding orbitals and have a bonding character.

The origin of the cohesive energy of a metal can now be obtained. Suppose that the energy band spreads out symmetrically from the original atomic orbital energy and that the energy levels in the band are all equally spaced. (This is *not* true, but it is a

good starting point.) The electrons will feed into the energy levels in a band, following the Aufbau principle, with two electrons of opposing spins in each level. For bonding to occur, an *atomic* orbital must contain a single unpaired electron. Therefore, each atom in the progression illustrated in Figure 2.23 will contribute one electron to the energy band. When all atoms have contributed an electron the energy band will be half filled. The cohesive energy for a metal is due to this part filling of the energy band, because the electrons preferentially occupy the energy levels with a bonding character.

The bonding energy of a diatomic molecule is obtained by feeding two electrons into the bonding molecular orbital (Figures 2.7 and 2.24), to give a bonding energy of $2E_{\text{bond}}(\text{mol})$. The average energy of an electron in a half-filled energy band, E_{av} , can be equated (very roughly) to $E_{\text{bond}}(\text{mol})$. The bonding energy of a metal will be obtained by feeding two electrons into the average energy level in the band, to give a value for the bond energy in a metal, $2E_{\text{bond}}(\text{metal})$, approximately equal to $2E_{\text{bond}}(\text{mol})$ (Figure 2.24). The bond energy of a metal then should be of the same order of magnitude as the bond energy of a diatomic molecule of the metal. For example, the bond energy of the molecule Li_2 is calculated to be about 140 kJ mol^{-1} , and the energy

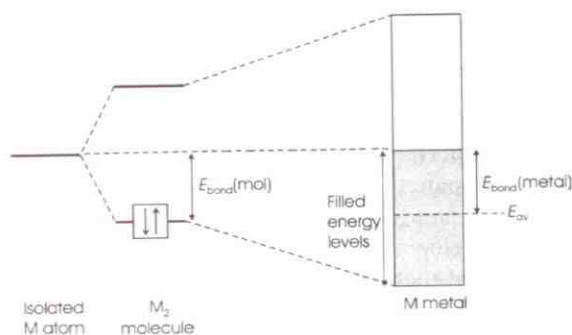

Figure 2.24 The bonding energy in a molecule, M_2 , compared with an isolated M atom, is due to filling the bonding molecular orbital while the antibonding orbital remains empty. In a solid metal, the bonding energy is due to filling the lower bonding character energy levels while leaving the upper antibonding character energy levels empty

of evaporation of Li metal, which should be similar to the cohesive energy, is about 100 kJ mol^{-1} .

An accurate value for the cohesive energy of a metal will require knowledge of the number and distribution of the energy levels in the band as well as of other factors that have not been described, and will vary from metal to metal. Band theory, described in Section 2.3.8, is needed to take this further and to account for the differences between one metal and another.

2.3.3 Atomic orbitals and energy bands

The gradual broadening of atomic orbitals into energy bands will happen to each of the atomic orbitals on each of the atoms in the crystal. The sharp energy levels applicable to an atom thus become translated into a set of bands. The separation of the bonding and antibonding molecular orbitals, and thus the strength of a covalent bond, is related to the degree to which the atomic orbitals are able to overlap. Similarly, the energy spread in an energy band is related to the possibility of orbital overlap and so to the extension of each orbital. The filled core electron orbitals are compact and are shielded from any interactions with orbitals on other atoms by the valence electron orbitals. No significant overlap of these orbitals with orbitals on other atoms is possible. Thus, core electron orbitals hardly broaden at all and form very narrow energy bands little different from those in a free atom. In contrast, the outer orbitals of adjacent atoms will interact strongly and the energy bands will be broad. In this respect, outer p orbitals are more condensed than are outer s orbitals and produce narrower bands. As an example, Figure 2.25 shows the schematic development of energy bands for a typical alkali metal such as sodium ($\text{Na}, 3s^1$). Energy bands that can be related directly to atomic orbitals are often given a similar terminology. Thus, the uppermost band in Figure 2.25 is called an s band or the 3s band.

Any d and f orbitals present are always shielded beneath outer s and p orbitals. They interact only weakly with orbitals on other atoms and form narrow d or f bands. The d and f electrons are

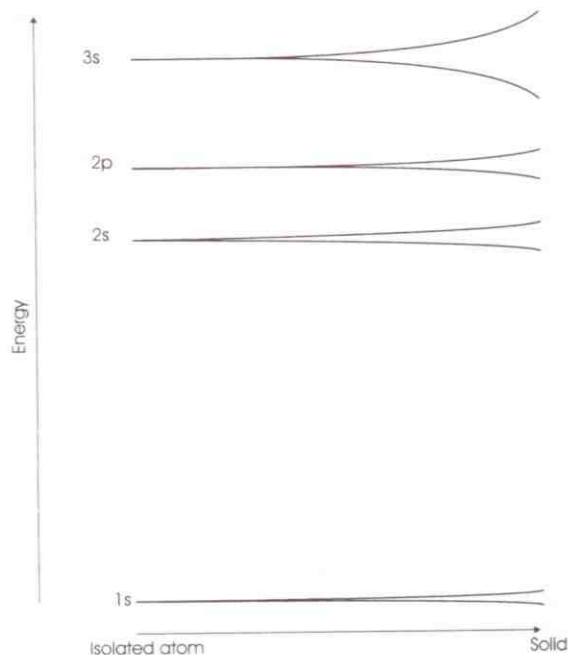

Figure 2.25 The development of energy bands from atomic orbitals for sodium metal. Isolated atoms (left-hand side) have sharp energy levels. In a solid, these are broadened into energy bands. Outermost orbitals broaden more than inner orbitals

sometimes best described as existing in narrow bands delocalised over the solid and sometimes as being localised in sharp atomic orbitals on individual atoms. Changes in temperature or pressure can make the behaviour of the electrons switch from one state to another. The d and f orbitals and bands do not play an important part in bonding but dominate the magnetic and optical properties of many solids.

2.3.4 Divalent and other metals

The cohesive energy in a metal such as sodium arises from the half-filled 3s band (Figure 2.25). An immediate difficulty arises when the neighbouring element to sodium, magnesium (Mg), with an electron configuration $[\text{Ne}] 3s^2$, is considered. If each magnesium atom contributes both s electrons to the s band then the band will be filled. The bonding and antibonding contributions will be equal, and no

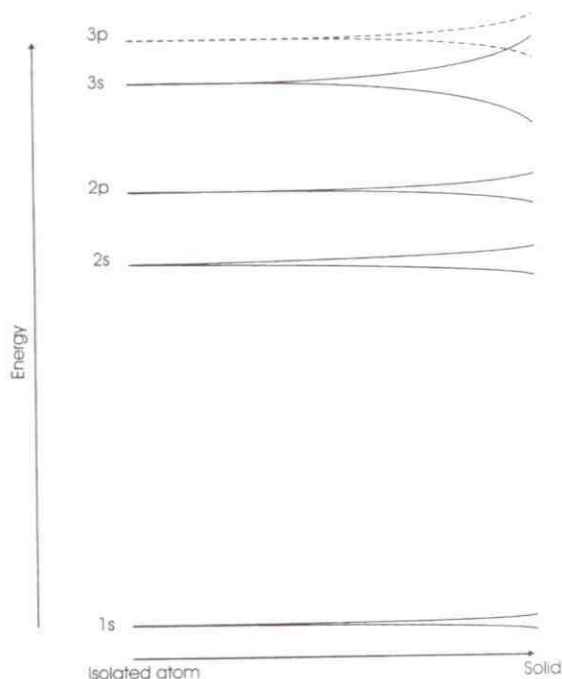

Figure 2.26 The development of energy bands from atomic orbitals for magnesium metal; the outermost 3s and 3p bands overlap in the metal

cohesion will result. A solid will not condense from the gas. This does not agree with commonplace observations; magnesium is clearly a metallic solid under normal temperatures and pressures. The answer to the puzzle is that the 3p orbitals, although empty on an isolated atom, broaden into a band that overlaps the 3s band (Figure 2.26). As magnesium atoms coalesce, electrons may initially enter the 3s band, but ultimately the highest-energy electrons in the 3s band spill over into lower-energy levels in the 3p band. The combined s and p band can hold eight electrons per atom. As each magnesium atom contributes two, these will mainly occupy bonding levels in partially filled bands. A solid metal will result.

The spreading of the energy bands associated with the outer orbitals increases for the heavier elements, simply because of their larger size and consequently greater interaction. Because of this, the outer orbitals on most of the heavier elements in

the periodic table are transformed into rather wide, overlapping, bands in the solid state. In addition, a glance at the electronic configurations of these heavier atoms reveals that, for most, the bands will be partly filled. Thus, the molecular orbital model explains why so many of the elements can condense together to form metallic solids.

Because the energy bands are derived from delocalised molecular orbitals the electrons in the energy band are delocalised over all of the atoms in the solid. The strong bonding direction imparted by the overlap of atomic orbitals to form covalent bonds is now lost. Metallic bonds are therefore expected to be nondirectional. Moreover, as the outer electron orbitals are now transformed into bands, the remaining core electron orbitals, whether broadened or not, are of a spherical shape. Thus, metals are characterised by the packing of spherical atoms. Spheres can pack most efficiently when each is surrounded by a large number (8 to 12) nearest neighbours (see Chapter 5). Thus, the model explains the high apparent valence of metals in crystals. Moreover, as the outer electrons are lost to individual atoms, one metallic element is much like another, so that alloys will be expected to form readily. Similarly, the development of energy bands is dependent upon the close approach of the atoms and not on the relative configuration of the atoms. This means that a liquid metal should have similar properties to a solid metal.

The most important characteristic of a metal is its ability to conduct electricity. The molecular orbital theory contains the idea that the electrons are delocalised throughout the crystal, which suggests that delocalised electrons are responsible for electrical conductivity. To develop this idea quantitatively it is necessary to use band theory.

2.3.5 The classical free-electron gas

Band theory started with a gross approximation: the idea that a metal contained a 'gas' of completely free electrons, uninfluenced by the other electrons or anything else. The model, an adaptation of the kinetic theory of gases, was very successful. The electrons were supposed to be 'flying about' in the

metal, in every direction, at random. The imposition of a voltage caused the random motion to be replaced by a drift in average motion that was equated to the electric current that flowed. This simple model predicted that a metal should obey Ohm's law and that the resistivity of the metal should increase slightly with temperature, as it does (see also Chapter 13).

However, it could not explain some important properties. In particular, the theory was unable to account for the fact that metals had a similar specific heat to insulators. If an electron gas occurs in metals, but not in insulators, it could be proved that metals should have a molar specific heat of about $4.5R$ whereas insulators would have a molar specific heat of only $3R$, where R is the gas constant.

2.3.6 The quantum free-electron gas

The advent of quantum theory suggested that the electrons in the metal, although still free, should be treated like waves. If this was so, the Schrödinger equation could be used to determine the energy of an electron in a metal. The only variables to be specified were the dimensions of the solid metal containing the electron and the potential energy of the electron in the metal. Mathematically, this is much simpler than the corresponding equations for molecular orbitals and is analogous to the hydrogen atom as described in Chapter 1.

As a first step, suppose that the potential energy is constant throughout the metal. To illustrate the results, take a one-dimensional case in which a single electron is confined to a line of length a . (This is often referred to as a 'particle in a box'.) The potential energy of the electron is set at zero on the line (or in the box) and at infinity at the extremities, so that the electron wave is completely trapped. The solutions in such a case show that the only allowed electron waves are standing waves, with nodes at the fixed ends of the line (Figure 2.27). The allowed wavelengths, λ , are given by:

$$\lambda = \frac{2a}{n} \quad (2.11)$$

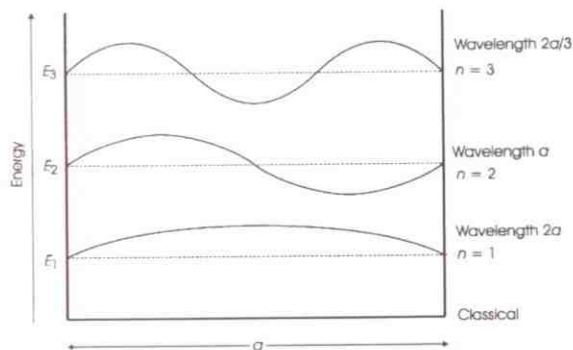

Figure 2.27 The energy levels of an electron confined to a line of length a . Quantum mechanics restricts the electron wave to fit into the length of the line, thus limiting the energy of the electron to discrete values corresponding to $n = 1, 2, 3$ and so on

where n is a quantum number that can take integer values $1, 2, 3, \dots$ and so on. The wave equation describing this situation is:

$$\psi = A \sin\left(\frac{n\pi x}{a}\right) = A \sin\left(\frac{2\pi x}{\lambda}\right) = A \sin kx \quad (2.12)$$

where A is a constant, $\sqrt{(2/a)}$, and k is called the wavenumber. It has quantised values given by:

$$k = \frac{2\pi}{\lambda} = \frac{n\pi}{a} \quad (2.13)$$

(In three dimensions k is a vector quantity, and is called the wave vector.)

The electron is confined not only to certain wavelengths but also to quantised energies, E_n :

$$E_n = \frac{k^2 h^2}{8\pi^2 m} = \frac{n^2 h^2}{8ma^2} \quad (2.14)$$

where E_n is the energy of the wave associated with quantum number n , and m is the mass of the electron. The form of the energy versus k graph is parabolic, as:

$$E = Bk^2$$

where B is a constant, $h^2/8\pi^2 m$ (Figure 2.28).

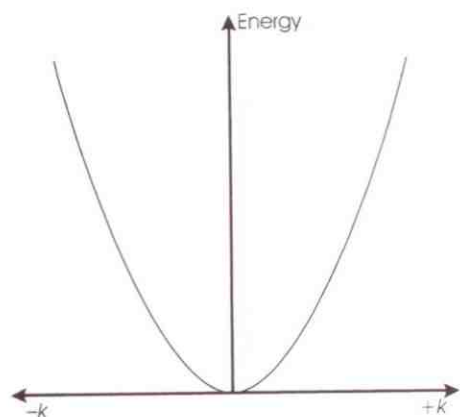

Figure 2.28 The relationship between the energy of an electron, E , confined to a line, and the wavenumber, k . The curve is a parabola as E is proportional to k^2

The energy of a single electron in a rectangular block of metal with sides of length a , b and c , lying along the three axes x , y and z , is:

$$E(n_x, n_y, n_z) = \frac{h^2}{8m} \left(\frac{n_x^2}{a^2} + \frac{n_y^2}{b^2} + \frac{n_z^2}{c^2} \right) \quad (2.15)$$

where n_x , n_y and n_z are the quantum numbers along the x , y , and z axes, equivalent to n in the one-dimensional case. For a cubic block of sides length a , this reduces to:

$$E(n_x, n_y, n_z) = \frac{h^2}{8ma^2} (n_x^2 + n_y^2 + n_z^2) \quad (2.16)$$

As described in Chapter 1, wavefunctions with the same energy are said to be degenerate. Thus, for a cubic container the solutions ($n_x = 1, n_y = 1, n_z = 2$), ($n_x = 1, n_y = 2, n_z = 1$) and ($n_x = 2, n_y = 1, n_z = 1$) are all of the same energy and so are degenerate. (This is analogous to the situation between the s , p and d orbital energies for a hydrogen atom.)

The degeneracy means that the number of energy levels within a particular energy range is not a constant but increases with increasing values of k . In order to solve the problem of the electron contribution to the specific heat of a metal it is necessary to discover how many energy levels (i.e.

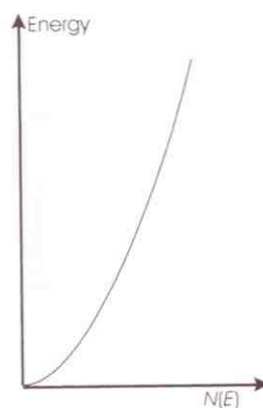

Figure 2.29 The form of the density of states, $N(E)$, for a free electron in a metal

wavefunctions, or orbitals) occur in any particular range of energy dE between the energies E and $E + \delta E$. The result for a cube of volume V is:

$$N(E) = 2\pi V \left(\frac{8m}{h^2} \right)^{3/2} E^{1/2}. \quad (2.17)$$

This is called the density of states function, $N(E)$. This curve, like the curve of E against k , is also parabolic in form (Figure 2.29). The number of energy levels in a small range of energy increases sharply as the energy increases. As each energy level can accommodate two electrons, the number of electrons in an energy interval between E and $E + \delta E$ is double that in Equation (2.17).

2.3.7 The Fermi energy and Fermi surface

The discussion in the previous section considered the energy of a single electron in the metal. Extension to many electrons employs a similar strategy to the orbital approximation in Chapter 1. The 'one-electron' energy levels calculated above are populated with the additional electrons, following the Pauli exclusion principle and the Aufbau principle. Thus, each level can hold just two electrons, with differing spins. To determine the overall distribution, electrons are allocated two at a time to the

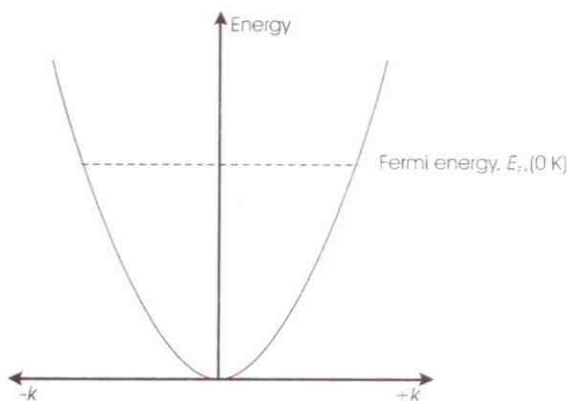

Figure 2.30 The Fermi energy, E_F , is the uppermost energy level filled at 0 K. At higher temperatures, the electrons are distributed over nearby energy levels and the boundary becomes less sharp

energy levels, starting with the lowest energy up to a maximum energy governed by the number of electrons available. At absolute zero, the uppermost occupied level, labelled E_F in Figure 2.30, is at the Fermi energy. In three dimensions this highest filled energy level takes the form of a surface, the Fermi surface. The value of the Fermi energy can be found by integrating Equation (2.17) between the limits of $E = 0$ and $E = E_F$. This leads to the result:

$$E_F = \left(\frac{h^2}{8m} \right) \left(\frac{3N}{\pi V} \right)^{2/3}$$

where h is the Planck constant, m represents the electron mass and N is the number of free electrons in a volume V of metal.

At temperatures above absolute zero, the electrons are liable to gain energy. However, it is not possible for electrons in lower levels to move into adjacent levels, as these are already filled. Only those electrons with the highest energies, near to the Fermi surface, can move to higher energy levels. The vast body of electrons remains untouched by the rise of temperature because no empty energy levels are available to them. The statistics that govern the distribution of electrons between the energy levels are called Fermi – Dirac statistics. Particles obeying these statistics, such as electrons,

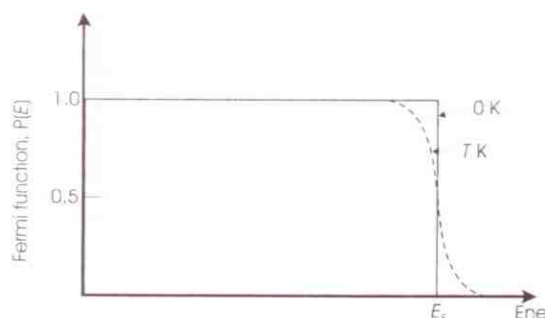

Figure 2.31 The Fermi function, $P(E)$, giving the probability of the occupation of an energy level as a function of the energy, E . At 0 K, the probability is 1.0 up to Fermi energy, E_F , and thereafter is 0. At higher temperatures, the curve changes smoothly from 1.0 to 0.

are called fermions. The distribution of electrons temperatures other than 0 K is given by the Fermi function:

$$P(E) = \left[\exp\left(\frac{E - E_F}{kT}\right) + 1 \right]^{-1} \quad (2.1)$$

where $P(E)$ is the probability that an energy level is occupied by an electron at temperature T (Figure 2.31; see also Chapter 15 and Section S4.12). At $T = 0$ K, $P(E) = 1$ for $E < E_F$, and $P(E) = 0$ for $E > E_F$. We also note from Equation (2.18) that at $E = E_F$, $P(E) = \frac{1}{2}$. Thus the Fermi level in metals above 0 K can be defined as the energy for which $P(E) = \frac{1}{2}$.

The variation of the population of electrons in metal with energy E , $N_e(E)$, is simply given by the density of states function, $N(E)$, multiplied by 2 (each energy level can hold two electrons) multiplied by the probability that the energy level will be occupied (the Fermi function), $P(E)$. That is:

$$N_e(E) = 4\pi V \left(\frac{8m}{h^2} \right)^{3/2} E^{1/2} \left[\exp\left(\frac{E - E_F}{kT}\right) + 1 \right]^{-1}$$

This curve, which is a superposition of the density of states curve (Figure 2.29) and the Fermi function (Figure 2.31) is drawn in Figure 2.32.

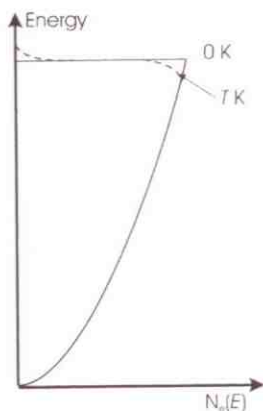

Figure 2.32 The population density, $N_e(E)$, for free electrons in an energy band at 0 K and a higher temperature, T K

Because only a few higher energy levels will be populated by electrons as the temperature rises, the electrons do not contribute appreciably to the specific heat. Thus, the electronic heat capacity is almost negligible, and a major drawback of the classical theory has been corrected.

2.3.8 Energy bands

In the free-electron approach, the electrons were not supposed to interact with one another or the atomic nuclei present. (In fact, the calculations are made for a single electron, as in the hydrogen atom.) This is obviously a gross approximation. Later theories suppose that the electrons move in a potential that is more representative of the crystal structure. The potential is described as a periodic potential. This means that it mirrors the positions of the atoms in the solid. It is designed so that the probability of encountering the electron is low at atomic nuclei and high between atoms.

The first solution to the way in which a periodic potential modifies the free electron model was given by Bloch in 1928. The solution of the Schrödinger equation was found to consist of the free-electron wavefunctions multiplied by a function with the

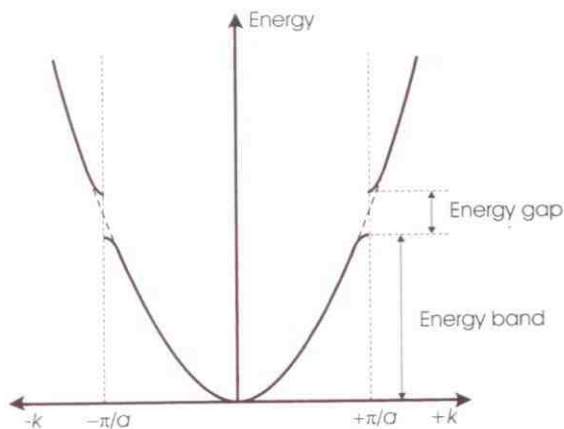

Figure 2.33 The one-dimensional free-electron curve of energy, E , versus wavenumber k ; it is 'broken up' into energy bands separated by energy gaps because of the periodic potential of atomic nuclei of separation a

same periodicity as the crystal structure. These wave equations are called Bloch functions. A number of sophisticated potential models are now used routinely to calculate the properties of metals (see the Further Reading section).

Regardless of the exact potential used, certain generalisations are found always to hold. First, if the potential is weak, the wavefunctions must be similar to the free-electron wavefunctions. Second, regardless of the potential, at small values of the wave vector, k , wavefunctions are almost the same as the free-electron wavefunctions. Small values of k correspond to electron waves with a long wavelength and low energy. At this extreme, the energy levels are closely spaced and vary with k in a parabolic fashion. The electron is 'not aware' of the atoms in the solid.

As the wavenumber gets larger, the energy versus k curve is distorted away from a parabolic shape. Ultimately, no solutions to the wave equation are found to describe the situation, and the energy versus k curve is broken (Figure 2.33).

The origin of this break is well understood. Electron waves in a solid behave in a similar way to X-rays and other waves in any medium. When a wave encounters an object much smaller than its wavelength, it barely changes the wave propagation. However, when a wave encounters an object of the

same dimensions as the wavelength, considerable interaction occurs. The wave is diffracted (covered in more detail in Chapter 14). In the case of electron waves in a solid, most waves will pass straight through the solid. However, waves with a wavelength similar to the repeat distance between the atoms in the solid will be diffracted by the structure.

Although diffraction is a complicated process, in the present situation the effects of diffraction can be equated to reflection. The circumstances for diffraction to occur are given by Bragg's law:

$$n\lambda = 2d \sin \theta \quad (2.19)$$

where n is an integer taking values 1, 2, 3, and so on; λ is the wavelength of the wave; d is the spacing of the planes of atoms; and θ is the diffraction angle (Figure 2.34; see also Chapter 5).

In terms of the wave vector, k , the Bragg equation can be written as:

$$\frac{\pi n}{k} = d \sin \theta \quad (2.20)$$

An electron wave normally incident upon planes of atoms of spacing a has a diffraction angle of 90° (Figure 2.35). From Equation (2.20), with n taking

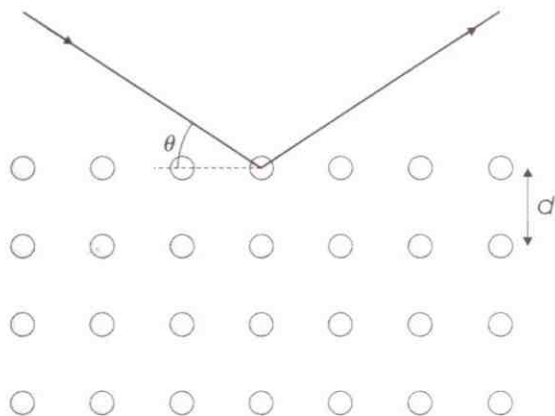

Figure 2.34 Electron waves are diffracted by planes of atoms separated by the interplanar spacing d when the Bragg equation ($n\lambda = 2d \sin \theta$) is obeyed

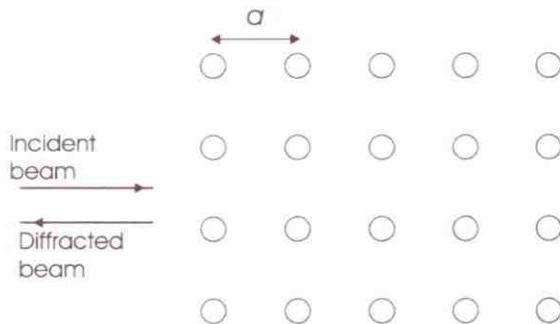

Figure 2.35 An electron wave normal to planes of atoms of interplanar spacing a will be diffracted back on itself when the wavelength λ is equal to $2na$ and the wave vector k is equal to $2n\pi/a$

integer values, we find that diffraction of the wave occurs at values of the wave vector given by:

$$k = \pm \frac{\pi}{a}, \quad \pm \frac{2\pi}{a}, \quad \pm \frac{3\pi}{a}, \dots \quad (2.21)$$

Waves with these wave vectors will not be able to pass through the crystal.

The more accurate one-dimensional E versus k curve for this situation is drawn in Figure 2.36. When the wavelength of the electron wave corresponds to those given by Equation (2.21) the wave

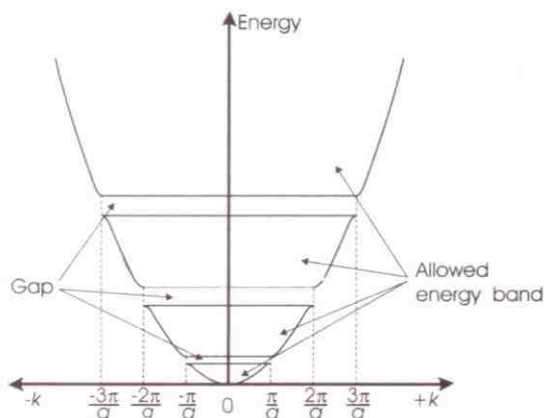

Figure 2.36 Energy bands for electrons in a one-dimensional crystal with atom spacing a . Energy gaps occur when the electron wave is diffracted and cannot pass through the crystal

cannot propagate through the crystal. Propagation will occur again when the wave vector increases slightly. Substitution of these values into the Schrödinger equation reveals that the change in wave vector is accompanied by an energy jump from a lower value to a higher value. It is not possible for an electron to have an energy value lying between the two extremes. This is described by saying that an electron can exist within a band of allowed energies. These bands are separated from each other by bands of forbidden energies.

2.3.9 Brillouin zones

The discontinuities in the energy versus k curve resulting from electron diffraction mark the boundaries of Brillouin zones. The first Brillouin zone in the one-dimensional case (Figure 2.36) extends from $k = \pi/a$ to $k = -\pi/a$. The second Brillouin zone extends from $k = \pi/a$ to $k = 2\pi/a$ on the positive side of the graph and from $k = -\pi/a$ to $k = -2\pi/a$ on the negative side (Figure 2.37). The third, fourth and subsequent Brillouin zones can be similarly located. The concept of a Brillouin zone is an abstract concept, as the zones exist in a space

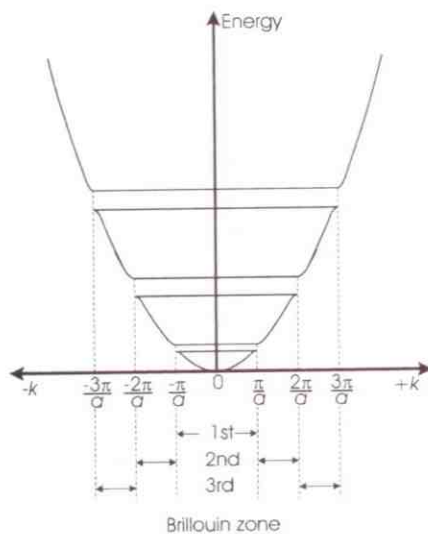

Figure 2.37 The first three Brillouin zones for a one-dimensional crystal with atom spacing a

defined by the wave vector and the energy of the electron. The wave vector is proportional to the velocity and the momentum of the electron, and these zones are sometimes described as existing in velocity or momentum space.

In three dimensions the geometry becomes more complicated. Planes of atoms, with spacing b , at an angle to the planes in Figure 2.35, will generate a set of Brillouin zones that extend from $k = \pi/b$ to $k = -\pi/b$, and so on. The positions of the Brillouin zone boundaries thus mirror the structure of the solid. A real crystal will therefore have a set of nested Brillouin zones that have polyhedral shapes. These shapes are closely related to the symmetry of the crystal structure. The Fermi energy will now be represented by a surface in energy versus k space. Far from the Brillouin zone boundaries, this surface is spherical. However, the shape is distorted near to the Brillouin zone boundaries. The Fermi surface can exist in more than one Brillouin zone if it lies below the energy gap in one direction and above the energy gap in another. Brillouin zone theory is central to the explanation of the dynamics of electrons in metals.

2.3.10 Alloys and noncrystalline metals

Alloys resemble pure metallic elements. In a solid in which metallic bonding is of importance the outer electrons on the atoms held together are shared communally. Provided all of the atoms present in the alloy can lose outer electrons in this way, the material will resemble a metal. Moreover, the loss of the outer electrons removes the main chemical distinguishing feature of an element. Thus, in alloys the individual chemical variations between the components will be suppressed. A significant difference between elemental metals and alloys, however, will be the band structure and the extent to which the bands are filled with electrons. For example, sodium has a half-filled 3s band whereas magnesium has partly filled overlapping 3s and 3p bands. The band structure of sodium – magnesium alloys is therefore expected to depend on alloy composition. In general, this is true for all alloys, and the chemical and physical properties of alloys

are closely related to the composition of the alloy and to how the electrons donated by the metal atoms interact with the Brillouin zone boundaries.

An important aspect of metallic bonding is that it operates in the liquid state. Mercury is no less a metal when liquid than when it is solid. In this context, the properties of a liquid metal that are characteristically metallic are due to the partly filled upper band of energy levels.

The molecular orbital approach to metallic bonds explains this. The spreading of atomic orbitals into energy bands is not limited to an ordered crystalline array of atoms but hinges on close approach of atoms. The main features of the energy bands in a material are derived from the geometry of the nearest-neighbour atoms only. For many metals this geometry does not change greatly in a non-crystalline material compared with that of a crystal. For example, silicon atoms bond to four neighbours arranged tetrahedrally in crystals and in noncrystalline silicon. In the crystalline state the tetrahedra are linked together in a completely ordered way throughout the solid, whereas in the noncrystalline state the tetrahedra do not show this long-range order. Similarly, the number of nearest neighbours to any sodium atom in a crystal of sodium metal (six) is similar to the number in the liquid state. Mercury, although having a more complex crystal structure, has six near neighbours in the solid and the liquid. Thus, the energy band arrangement in a crystal or a liquid will be similar.

The filling of the uppermost energy band is dependent on the atoms involved. Again, this will not depend on the order of the atoms, only on the overlap of the orbitals to allow collective pooling of electrons.

Thus, the simple models presented above still apply to liquid metals as well as to metallic glasses and other noncrystalline materials. However, Brillouin zones will not occur in liquids or glasses, as they are features of crystalline arrays.

2.3.11 Bands in ionic and covalent solids

In the discussion of ionic and covalent bonding, the spreading of atomic orbitals into bands has been

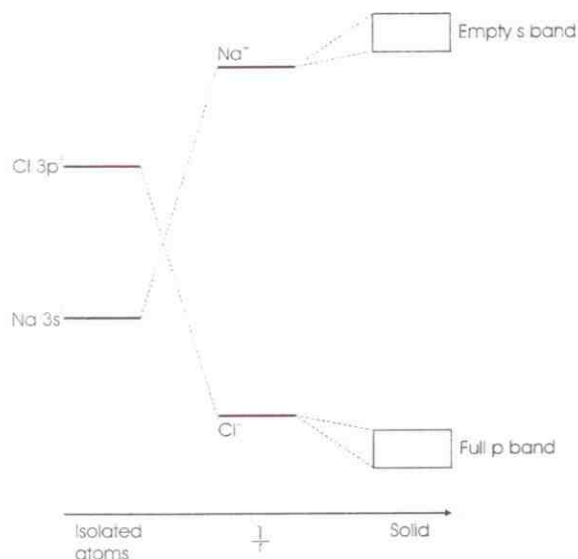

Figure 2.38 Energy bands of isolated atoms in sodium chloride (NaCl). As the spacing between the atoms, r , decreases, first ionisation occurs and then energy bands develop. These are narrow and widely separated, as expected from the ionic model of bonding

ignored. It is reasonable to question this and re-examine ionic and covalent solids.

Consider the archetypal ionic compound, sodium chloride (NaCl). A sketch of the development of bonding in this compound is shown in Figure 2.38. To the left, the constituents are isolated from each other. The lowest energy corresponds to Na and Cl atoms in their respective ground states. (For clarity, the core energy levels of both atoms have been ignored and only relative changes in energy are included in Figure 2.38.) As the interatomic separation decreases, a critical separation is reached at which energy is gained by the transfer of an electron from sodium to chlorine to form Na^+ and Cl^- ions. As the ions condense into a crystal the energy of the Cl^- ions falls below that of the Na^+ ions. This occurs at an interatomic separation of approximately 1.0 nm. However, calculations show that even at this close spacing the energy levels are still similar to those on isolated ions. As the interatomic spacing decreases further, the electron orbitals overlap. The electrons with opposed spins will

tend to lose energy whereas those with parallel spins will tend to gain energy. These are the familiar bonding and antibonding interactions and cause the narrow energy levels to broaden into bands. However, the ionic electron distribution is unchanged. Thus the band that develops on the Cl^- ions, the 3p band, is full, and the band that develops on the Na^+ ions, the 3s band, remains empty. Thus the ionic model is still a good model for the bonding in NaCl.

In the case of a covalently bonded crystal such as germanium (Ge), with an outer electron configuration of $[\text{Ar}] 4s^2 4p^2$, a modification to the molecular orbital model is again needed. As an example, consider germanium crystals, which are composed of a tetrahedral array of germanium atoms linked by sp^3 hybrid bonding. In the case of isolated atoms, use of atomic orbitals and energy levels is appropriate (Figure 2.39). As the atoms are brought together, these orbitals interact to form four degenerate sp^3 hybrid orbitals. Each sp^3 orbital on an atom contains one electron, and overlap with adjacent orbitals causes strong bonds with a tetrahedral geometry to form. As the atoms approach further, each single sp^3 energy level widens into a narrow band, the lower half of which is bonding and the upper part of which is antibonding. The band derives from the overlap of four sp^3 energy levels

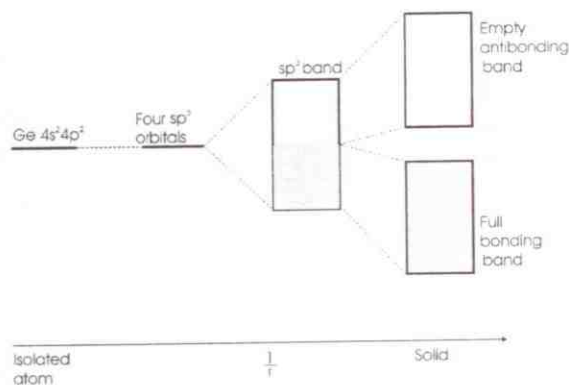

Figure 2.39 Energy bands from isolated atoms in germanium (Ge). As the spacing between the atoms, r , decreases, first orbital hybridisation occurs and then energy bands develop. These are broad and separated by a narrow energy gap, as expected from the covalent model of bonding

and is able to contain a maximum of eight electrons. As each atom donates one electron per sp^3 energy level, the band is half full. Continued approach causes the antibonding part of the band to increase in energy because of the repulsion between the parallel electrons and causes the bonding part to decrease in energy because of the favourable interaction between the spin-paired electrons. At a critical separation, the single band is split into two bands separated by an energy gap. When the chemistry of the material is discussed, the lower of these bands is usually called a bonding band and the upper an antibonding band. In semiconductor physics they are referred to as the valence band and conduction band, respectively. The electrons, one in each sp^3 orbital, that combine in a covalent bond end up in the lowest bonding band, which will be completely full. The upper antibonding band will be completely empty. The cohesive energy in these crystals is, in fact, due to the appearance of the energy gap between the upper (empty) and lower (filled) bands.

The elements carbon (diamond), silicon, germanium, and one form of tin, α -tin, all crystallise with the same structure. The size variation of this series of atoms modifies the band formation in a predictable way. The smallest atom, carbon, has the smallest degree of orbital interaction and hence the narrowest bands. The energy gap is therefore large, and diamond has a very high cohesive strength. As the atoms increase in size, the orbital interactions increase, bands widen, the gap narrows and the cohesive energy falls. Unlike diamond, α -tin is a weak solid and is easily crushed.

Although this description is quite different from that of covalent bonding, the separation of the energy bands in the solid is similar to the separation of the bonding and antibonding molecular orbitals that would be found on a diatomic C_2 , Si_2 , Ge_2 or Sn_2 molecule with a similar interatomic separation to that of the atoms in the crystal. The covalent bond picture is, therefore, quite similar to the band picture. In the covalent model, the bond energy is related to the separation of the molecular orbitals. In the solid, the cohesive energy is related to the energy of the bands that have developed from the molecular orbitals. With this limitation in mind,

the covalent bonding model is adequate for many solids.

Answers to introductory questions

What are the principle geometrical consequences of ionic, covalent and metallic bonding?

Ionic bonding is long-range in operation, and the electrostatic force that controls the attraction or repulsion is the same in all directions. Thus, the most important geometrical feature of ionic bonding is that it is nondirectional. Atoms linked by ionic forces pack together to minimise the various attractive and repulsive forces so that cations are surrounded mainly by anions, and anions by cations.

Atoms that are linked by electron-pair bonds are positioned so that orbital overlap is maximised. The orbitals used are also sensitive to bond overlap and hybridisation, so that atomic orbitals frequently mix to give hybrid orbitals with greater overlapping power. The shapes of atomic orbitals and hybrid orbitals are quite definite and point in fixed directions. This leads to the fact that covalent bonding is directional. From a geometrical point of view, the array of covalent bonds in a solid resembles a net.

The formation of metallic bonds requires that the atoms lose outer electrons to a common electron band that runs throughout the solid. This means that atoms lose a large part of their chemical identity and resemble round spheres. The geometrical consequence of this is that atoms pack together like spheres and the bonding is nondirectional. Atoms simply pack together to minimise the space occupied.

What orbitals are involved in multiple bond formation between atoms?

Atoms linked by σ and π bonds at the same time are linked by multiple bonds. For example, multiple bonding in the nitrogen molecule, N_2 ($N \equiv N$) comprises the p_x orbitals combined in an end-on fashion

to form a σ bond, and the p_y and p_z orbitals combined in a sideways manner to form two π bonds. Note that the traditional representation of three bonds drawn as three horizontal lines does not make it clear that two different bond types exist in N_2 . In the case of the oxygen molecule, O_2 ($O=O$) the p_x orbitals overlap end on to form a σ bond, and the p_y orbitals overlap in a sideways fashion to form a π bond. As with nitrogen, the conventional representation of the double bond does not reveal that two different bond types are present.

Multiple bonding is of considerable importance in carbon compounds and figures prominently in the chemical and physical properties of polymers.

What are allowed energy bands?

The electron energy levels in a solid are so closely spaced that they can be treated as a continuum. This forms an energy band. The simple electron gas model of a solid has only one band of energies. When the potential due to the atomic nuclei is taken into account the single free-electron band is broken up into a number of 'allowed' energy bands separated by regions that have no energy levels available to the electrons. Allowed energy bands are thus closely spaced sets of energy electron levels that can be occupied collectively by the electrons surrounding the atoms in a solid.

Further reading

The following references greatly expand the material in this chapter. The first two textbooks below merit reading for a broad-based introduction to the ideas contained in this chapter.

- L. Pauling, 1960, *The Nature of the Chemical Bond*, 3rd edn, Cornell University Press, Ithaca, NY.
- W.B. Pearson, 1972, *The Crystal Chemistry and Physics of Metals and Alloys*, Wiley-Interscience, New York.
- P.W. Atkins, 1981, *Quanta*, 2nd edn, Oxford University Press, Oxford.
- W.A. Harrison, 1980, *Electronic Structure and the Properties of Solids*, W.H. Freeman, New York.

A. Cottrell, 1988, *Introduction to the Modern Theory of Metals*, The Institute of Metals, London.

A critical account of the ionic model, particularly with respect to calculations and structures, is given by:

M. O'Keeffe, 1981, 'Some Aspects of the Ionic Model of Crystals', in *Structure and Bonding in Crystals, Volume 1*, eds M.O'Keeffe and A. Navrotsky, Academic Press, London, pp. 299 – 322.

M. O'Keeffe, B.G. Hyde, 1985, 'An Alternative Approach to Non-molecular Crystal Structures', *Structure and Bonding* **61**, 77.

Textbook errors in the discussion of lattice energies are discussed in:

D. Quane, 1970, 'Textbook Errors, 98: Crystal Lattice Energy and the Madelung Constant', *Journal of Chemical Education* **47**, 396.

Ionic radii are discussed and tabulated in:

R.D. Shannon, C.T. Prewitt, 1969, 'Effective Ionic Radii in Oxides and Fluorides', *Acta Crystallogr.* **B25** 925, 1969; 1970, 'Revised Values of Effective Ionic Radii', *Acta Crystallogr.* **B26** 1046.

R.D. Shannon, 1976, 'Revised Effective Ionic Radii and Systematic Studies of Interatomic Distances in Halides and Chalcogenides', *Acta Crystallogr.* **A32** 751.

The calculation of crystal energetics is described in:

C.R.A. Catlow, 1987, 'Computational Techniques and the Simulation of Crystal Structures', in *Solid State Chemistry Techniques*, eds A.K. Cheetham and P. Day, Oxford University Press, Oxford, Ch. 7.

Problems and exercises

Quick quiz

- The concept of the 'valence' of an atom refers to:
 - The charge on an ion
 - The strength of the chemical bonds formed
 - The combining ability of an atom
- A cation is:
 - An atom that has gained a small number of electrons
 - An atom that has lost a small number of electrons
 - A charged atom stable in solutions
- An anion is:
 - An atom that has lost a small number of electrons
 - An atom that has gained a small number of electrons
 - A charged atom stable in solutions
- Which of the following is a trivalent cation?
 - V^{3+}
 - V^{4+}
 - V^{5+}
- Ionic bonds are formed by which of the processes?
 - Electron sharing
 - Electron transfer
 - Electron delocalisation
- A key feature of an ionic bond is that it is:
 - Strongly directional
 - Completely nondirectional
 - Acts between identical atoms
- The Madelung energy is:
 - The bond energy of the crystal
 - The lattice energy of an ionic crystal
 - The electrostatic energy of an ionic crystal
- The reduced Madelung constant of crystals:
 - Varies widely from one structure to another
 - Is similar for all structures
 - Depends on the charges on the ions in the structure
- The lattice energy of an ionic solid is:
 - The sum of electrostatic and repulsive energies
 - The minimum of the electrostatic and repulsive energies
 - The difference between the electrostatic and repulsive energies

- 10 Lone pair ions have:
(a) A pair of electrons in outer orbitals
(b) A pair of s electrons outside a closed shell
(c) A pair of p electrons outside of a closed shell
- 11 Cations are generally:
(a) Smaller than anions
(b) Bigger than anions
(c) The same size as anions
- 12 A cation gets:
(a) Larger as the charge on it increases
(b) Smaller as the charge on it increases
(c) Remains the same whatever the charge
- 13 Covalent bonds are formed by which of the processes?
(a) Electron sharing
(b) Electron transfer
(c) Electron delocalisation
- 14 Covalent bonds are:
(a) Strongly directional
(b) Completely nondirectional
(c) Variable in direction
- 15 Covalent bonds are also called:
(a) Molecular orbitals
(b) Hybrid orbitals
(c) Electron-pair bonds
- 16 A σ bond is characterised by:
(a) Being formed between identical atoms
(b) Being formed by two s orbitals
(c) Radial symmetry about the bond axis
- 17 A π bond is characterised by:
(a) Being formed by two p orbitals
(b) Reflection symmetry about the bond axis
(c) Being formed between different atoms
- 18 Bonding molecular orbitals have:
(a) The same energy as antibonding orbitals
(b) A lower energy than antibonding orbitals
(c) A higher energy than antibonding orbitals
- 19 An asterisk marks:
(a) Antibonding orbitals
(b) Bonding orbitals
(c) Nonbonding orbitals
- 20 A polar covalent bond:
(a) Forms between different sized atoms
(b) Involves ions linked with molecular orbital
(c) Has the electron pair unevenly distributed in the molecular orbital
- 21 The electronegativity of an atom is a measure of its tendency to:
(a) Attract electrons
(b) Repel electrons
(c) Form a covalent bond
- 22 Strongest covalent bonds form:
(a) When the orbitals are of the same type
(b) When the orbitals overlap maximally
(c) When the orbitals are symmetrically arranged
- 23 A hybrid orbital is:
(a) An overlapping pair of orbitals
(b) A combination of orbitals on adjacent atoms
(c) A combination of orbitals on a single atom
- 24 sp^2 hybrid orbitals:
(a) Point towards the vertices of a tetrahedron
(b) Point towards the vertices of a triangle
(c) Point towards the vertices of a cube
- 25 Multiple bonds between two similar atoms:
(a) Always consist of the same types of molecular orbital
(b) Always consist of the same types of hybrid orbital
(c) Always consist of different types of molecular orbital
- 26 Metallic bonds are formed by which of the following processes?
(a) Electron sharing
(b) Electron transfer
(c) Electron delocalisation

- 27 Metallic bonds:
- Only act between the same metallic elements
 - Only act between different metallic elements
 - Act between any metal atoms
- 28 An energy band is due to the spreading out of energy levels as a result of:
- The close approach of atoms
 - Chemical bonding
 - Molecular orbitals
- 29 The cohesive energy of a metal is due to:
- A partly filled energy band
 - An empty energy band
 - An overlap of energy bands
- 30 A metallic bond is predominantly:
- Strongly directional
 - Completely nondirectional
 - Partly directional
- 31 Wavefunctions are said to be degenerate if:
- They have different energies
 - They overlap
 - They have the same energy
- 32 The Fermi energy is:
- The uppermost energy level filled
 - The highest energy in a band
 - The energy of an electron in a band
- 33 Energy gaps in crystals can be thought of being as being a result of:
- The diffraction of electron waves
 - The bonding of electrons
 - The localisation of electron waves
- 34 Energy bands can form:
- Only in crystals
 - Only in solids
 - In solids and liquids
- 35 Energy bands form:
- Only in metals

- In all solids
- Only in electrical conductors

Calculations and questions

- 2.1 Write out the electron configuration of the ions Cl^- , Na^+ , Mg^{2+} , S^{2-} , N^{3-} , Fe^{3+} .
- 2.2 Write out the electron configuration of the ions F^- , Li^+ , O^{2-} , P^{3-} , Co^{2+} .
- 2.3 Write the symbols of the ions formed by oxygen, hydrogen, sodium, calcium, zirconium and tungsten.
- 2.4 Write the symbols of the ions formed by iron, chlorine, aluminium, sulphur, lanthanum, and tantalum.
- 2.5 Use Equation (2.7) to calculate the lattice energy of the ionic oxide CaO , which has the *halite* (NaCl) structure; $\alpha = 1.75$, $n = 9$, $r_0 = 0.240$ nm.
- 2.6 Use Equation (2.7) to calculate the lattice energy of the ionic halides NaCl and KCl , which have the *halite* (NaCl) structure; $\alpha = 1.75$, $n = 9$, $r_0(\text{NaCl}) = 0.281$ nm, $r_0(\text{KCl}) = 0.314$ nm.
- 2.7 Use Equation (2.7) to calculate the lattice energy of the ionic halides NaBr and KBr , which have the *halite* (NaCl) structure; $\alpha = 1.75$, $n = 9$, $r_0(\text{NaBr}) = 0.298$ nm, $r_0(\text{KBr}) = 0.329$ nm.
- 2.8 Determine the number of free electrons in gold, assuming that each atom contributes one electron to the 'electron gas'. The molar mass of gold is 0.19697 kg mol $^{-1}$, and the density is 19281 kg m $^{-3}$.
- 2.9 Determine the number of free electrons in nickel, assuming that each atom contributes two electrons to the 'electron gas'. The molar mass of nickel is 0.05869 kg mol $^{-1}$, and the density is 8907 kg m $^{-3}$.
- 2.10 Determine the number of free electrons in copper, assuming that each atom contributes

- one electron to the 'electron gas'. The molar mass of copper is $0.06355 \text{ kg mol}^{-1}$, and the density is 8933 kg m^{-3} .
- 2.11 Determine the number of free electrons in magnesium, assuming that each atom contributes two electrons to the 'electron gas'. The molar mass of magnesium is $0.02431 \text{ kg mol}^{-1}$, and the density is 1738 kg m^{-3} .
- 2.12 Determine the number of free electrons in iron, assuming that each atom contributes two electrons to the 'electron gas'. The molar mass of iron is $0.05585 \text{ kg mol}^{-1}$, and the density is 7873 kg m^{-3} .
- 2.13 Using Equation (2.16) calculate the lowest energy level of a free electron in a cube of metal with edge length 1 cm and compare this with the thermal energy at room temperature, given by kT , where k is the Boltzmann constant and T is the absolute temperature.
- 2.14 Estimate the Fermi energy of silver; the molar mass of silver is $0.1079 \text{ kg mol}^{-1}$, the density is 10500 kg m^{-3} and each silver atom contributes one electron to the 'electron gas'.
- 2.15 Estimate the Fermi energy of sodium; the molar mass of sodium is $0.02299 \text{ kg mol}^{-1}$, the density is 966 kg m^{-3} and each sodium atom contributes one electron to the 'electron gas'.
- 2.16 Estimate the Fermi energy of calcium; the molar mass of calcium is $0.04408 \text{ kg mol}^{-1}$, the density is 1530 kg m^{-3} and each calcium atom contributes two electrons to the 'electron gas'.
- 2.17 Estimate the Fermi energy of aluminium; the molar mass of aluminium is $0.02698 \text{ kg mol}^{-1}$, the density is 2698 kg m^{-3} , and each aluminium atom contributes three electrons to the 'electron gas'.
- 2.18 Covalent bonding describes well the bonding in small molecules. Explain how covalent bonding leads naturally to the concept of definite molecular geometry. [Note: answer is not provided at the end of this book.]
- 2.19 The electronic configuration of atom sodium is $1s^2 2s^2 2p^6 3s^1$, and that of magnesium is $1s^2 2s^2 2p^6 3s^2$. Explain why crystals of both of these elements behave as metals. [Note: answer is not provided at the end of this book.]
- 2.20 Both the covalent theory and the ionic bonding theory can be used to guess the likely structure of a crystal. What coordination would be expected for the metal atoms or ions in the compounds ZnO and ZnS if they were covalent or ionic? In fact, the coordination polyhedra in both crystals are tetrahedral. What conclusions can you draw about the bonding in these solids? Regardless of coordination number, the ionic radii can be taken as: Zn^{2+} , 0.089 nm , O^{2-} , 0.124 nm , S^{2-} , 0.170 nm . [Note: answer is not provided at the end of this book.]
- 2.21 Draw the wavefunctions and the probability of locating an electron at a position x for an electron trapped in a one-dimensional potential well with zero internal potential and infinite external potential. [Note: answer is not provided at the end of this book.]
- 2.22 Make accurate plots of the Fermi function that expresses the probability of finding an electron at an energy E for temperatures of 0 K , 300 K , 1000 K and 5000 K . [Note: answer is not provided at the end of this book.]